

SHIPHANDLING

9

SHIP-HANDLING



TERMS AND GENERAL DEFINITIONS

Cavitation

That empty cavity, caused by the ship's displacement which is re-filled by water flowing down the ship's sides as the vessel moves ahead.

Con

'To take the con' is an old-fashioned term meaning to take *control* of the navigation of the vessel. It is still occasionally encountered, especially in the United States (conn). Submarines take the term 'conning' tower from the same word. It also implies *conducting* the navigation of the vessel by giving orders to the helmsman.

Drag

The frictional resistance caused by the ship's hull, drag in some parts of the world is also used to describe the difference between the forward and after draughts.

Headreach

The distance a vessel will continue to travel forwards after the main engines have been stopped is the headreach.

Helmsman

A person designated to steer the vessel manually is the helmsman. Helm orders used to apply to the tiller but after the First World War began to be accepted and related to the rudder.

List

A vessel which is not on an even keel in the upright position but heeled over to one side or another is listing.

Pitch

Defined as the axial distance moved forward by the propeller in one revolution through a solid medium. Measurement may be achieved by use of a pitchometer or by practical calculation in dry dock.

Pivot Point

A position aboard the vessel about which the ship rotates when turning is called the pivot point. In ships of conventional design (midships accommodation) the pivot point was approximately one-third the length of the vessel measured from forward when the ship was moving ahead. The pivot point changed when the vessel was going astern.

Quartermaster

In the modern merchant service a senior helmsman, is called a quartermaster especially in large passenger vessels. The term was previously applied to a petty officer who assisted the Master and officers.

Set

Set is a term used to describe the movement of a vessel which is being influenced by tide or current that the course being steered is not truly representative of the track the vessel is making. A vessel under such influence is often described as 'setting down'.

Sheer

(a) Defined as the angle that a ship will lie to her cable when at anchor.
 (b) Sheer may also be used to describe the upward curvature of the uppermost continuous deck – hence the term 'sheer strake'.
 (c) A vessel may also sheer away from her intended heading, so making a sharp alteration of course.

Squat

A term to describe the bodily sinkage of a vessel when under way and making way, squat is most noticeable in shallow water. Its value will vary proportionally to the square of the speed of the vessel. A vessel affected by squat may experience an increase in the forward draught and a subsequent change of trim when making way through the water, with possibly critical consequences to the handling and steerage of the vessel.

Stopping Distance

This is the minimum distance that a vessel needs to come to rest over the ground. Speed trials for new tonnage normally include test runs to provide information to watch officers showing the time and distance a vessel will take to stop (a) from full ahead after ordering main engines to stop, and (b) from crash full astern (emergency stop) (see Figure 9.1).

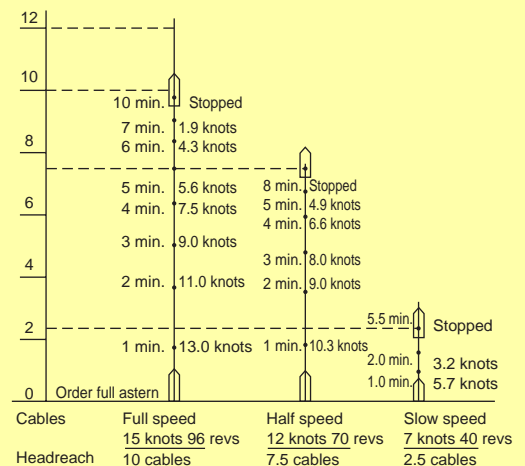

Figure 9.1 Stopping distance of vessel with particulars given.

18,000 tonnes	DWT
Draught forward	28'3"
Draught aft	30'3"
Crash stop	from full ahead to full astern

Way

When a vessel starts her main engines and begins to increase speed, she *gathers way*. When she is moving forward over the ground, irrespective of speed, she is *making way*. When the speed of the vessel will still affect and obtain a correct response from the rudder, she has *steerage way*. When the vessel is moving over the ground in the direction of the stern, under reverse propulsion, she has *sternway*. When a vessel is under way and making way and proceeding at a speed considered excessive for the prevailing conditions and situation, she has *too much way*. Finally, *under way*, as defined by the Regulations for the Prevention of Collision at Sea, means that a ship is not at anchor, or made fast to the shore, or aground.

Weather Side

This term refers to that side of the vessel exposed to the wind. Seas may be seen to break over the weather side as opposed to the lee side, which is the sheltered, favoured side of the vessel.

Yaw

Wind and sea astern of the vessel make 'yawing' about a real possibility, but this is not to say that the vessel would not behave in a similar manner if the weather was affecting the vessel from another direction. A vessel is said to yaw when, either by accident or design, her head falls off the course she is steering. Yawing is often a consequence of a following wind and sea.

FACTORS IN SHIP-HANDLING

The construction of the modern vessel will soon be such that controllable pitch propeller, bow thrust unit, stabilisers etc. will become the norm rather than novelties. However, the initial cost of installing specialised equipment of this nature is very high. Consequently, it will be some time before every owner accepts the new developments in equipment as standard.

Controllable

1. Main engine power.
2. Propeller or propellers. Fixed or controllable pitch.
3. Anchors.
4. Mooring ropes.
5. Rudder movement.
6. Bow thrust (if fitted).
7. Bow rudder (if fitted).
8. Tugs. (May be classed as controllable only as long as they respond as requested. Ship-handlers may find that tugs should be included in the following list of uncontrollable factors.)

Uncontrollable

1. The weather.
2. Tide and/or current.
3. Geographical features such as shallow water, floating obstructions, bridges and ice accretion.
4. Traffic density.

RUDDERS

Unbalanced Single Plate Rudder

The rudder stock and all pivot points (pintles and gudgeons), including the bearing pintle lie on a straight line. It is no longer used for large constructions because of alignment problems but is occasionally seen on smaller vessels—coastal barges and the like. The rudder is defined as being ‘unbalanced’ because the whole of the surface area is aft of the turning axis.

Semi-balanced ‘Mariner’ Type Rudder

This is a very popular rudder for modern tonnage, especially for the container type vessel and twin-screw vessels. The term ‘semi-balanced’ refers to the amount of surface area forward of the turning axis. If the proportion of surface area is less than 20 per cent forward of the axis, then the rudder is said to be semi-balanced.

Balanced Bolt Axle Rudder

The surface area of the rudder is seen to be proportioned either side of the ‘bolt axle’. In fact, the amount of surface area will vary but generally does not exceed 25 to 30 per cent forward of the axle. The advantage of a balanced rudder is that a smaller force is required to turn it, so that smaller steering gear may be installed at lower running cost. Ideally a reduction of torque is achieved because the rudder is turning about a more centralised position, which would not be experienced with, say, the unbalanced plate rudder already mentioned. Balanced rudders are of streamlined construction, which reduced drag.

Balanced Spade Type Rudder

A very widely used rudder, especially in vessels engaged on short voyages, such as ferries and Roll on–Roll off ships. It is, however, not common in other types of vessel. The main disadvantage is that the total weight of the rudder is borne by the rudder bearing inside the hull of the vessel.

Modern Advancers – Rudder Construction

The duct arrangement forward of the propeller has been tried and tested and shown to improve hull resistance as well as homogenise the flow on to the propeller. Today’s concept is to build in a reaction fin which will generate a reverse flow on to the propeller, and so improve the efficiency

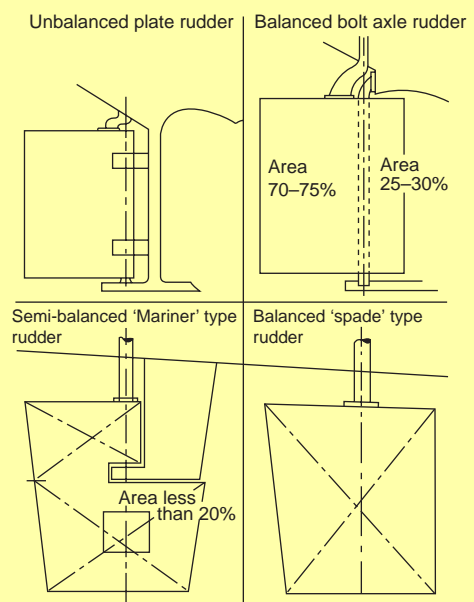
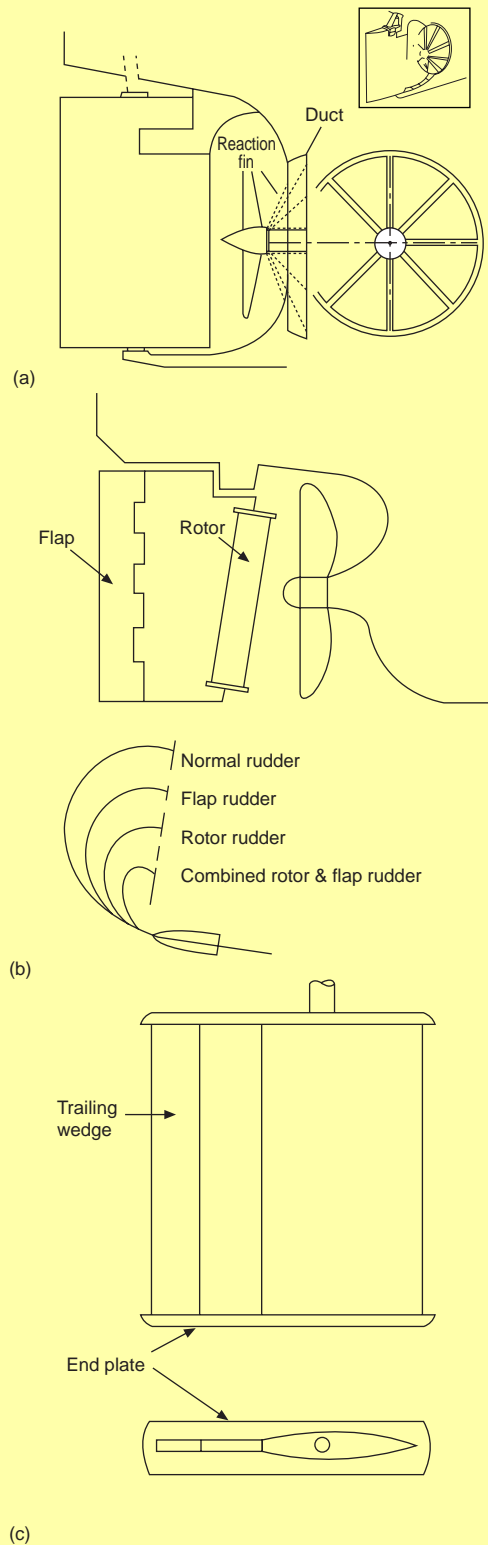

Figure 9.2 Types of rudder.



of the propeller by reducing transverse effects. This is a new development which is said to counter the effects of cavitation, reduce vibration and improve manoeuvrability.

Figure 9.3(a) (inset) shows a perspective view of the assembly.

Combined Rotor Cylinder with Improved Flap

Developments with rotors and flaps have greatly affected the turning circles and the manoeuvrability of vessels so equipped. The main disadvantage of these comparative recent advances within the marine industry are the additional maintenance problems because of the added moving parts.

Comparable turning arcs would seem beneficial to specialist craft which require more in the way of demanding manoeuvres. The cost of installation is an obvious disadvantage for the ship's owners, when compared with a normal rudder.

The Schilling Rudder

The 'schilling rudder' may be a fully hung spade or lower pintle simplex type, the balance is usually about 40 per cent. The rudder angle, at the full helm position is 70° - 75° , providing the vessel with the manoeuvrability to turn on its own axis.

The hydrodynamic shape of the rudder helps to extract the slipstream from the propeller at right angles when at the maximum helm position. This capability, which employs the main engine power, virtually acts as a stern thruster providing an effective sideways berthing facility. The build of the rudder is quite robust and with no moving parts it is relatively maintenance free, if compared to the rotor or flap types. Other features include the end plates which help to reduce pitching and absorb impact, so giving limited protection to the main body of the rudder. The 'trailing wedge' reduces the yaw of the vessel providing course stability with the minimum of helm movements necessary.

Further development has led to the 'VecTwin system' which employs twin rudders with the single propeller. A conventional wheel being used to operate rudders in tandem when engaged on passage and a single joystick control for more involved manoeuvres. The system can provide 70 per cent of the ahead thrust in a sideways direction and up to 40 per cent astern thrust. The large helm angles are capable of reducing the stopping distance by 50 per cent of a conventional ship when the rudders are in the 'reflectance', 'clamshell' position.

Figure 9.3 (a) Reaction fin with duct arrangement; (b) combined rotor cylinder with improved flap; (c) Schilling rudder.

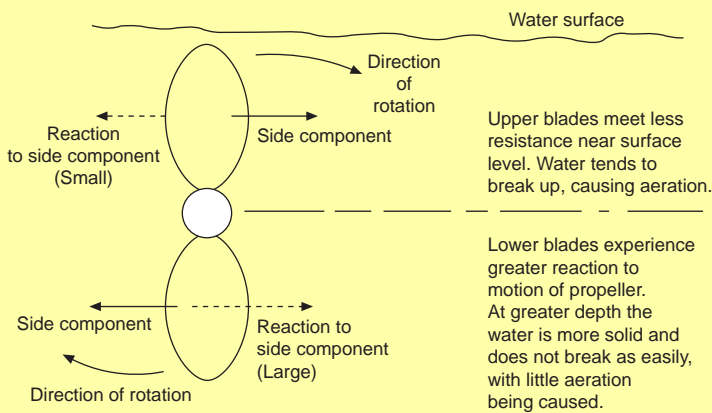

Figure 9.4 Forces acting on propeller blades.

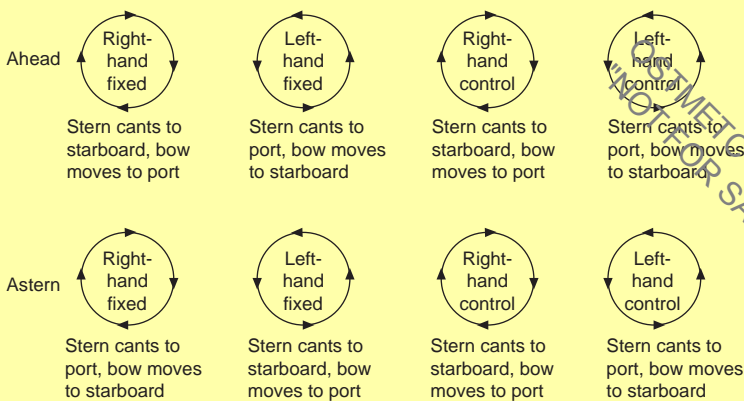

Figure 9.5 Propeller action when viewed from astern.

PROPELLERS

Right-hand Fixed Propeller

It is not within the scope of this text to discuss every type of propeller operational in present-day vessels. Some knowledge of the theory of the right-hand fixed propeller, however, should be sufficient for the reader to understand the properties of other propellers.

The marine propeller could be considered as something like a paddle wheel. Figure 9.4 shows the reaction and basic forces which affect the surface area of the propeller blades.

The resultant of the side components, caused by the rotation, may be resolved with the ahead motion created by the pitch angle of the blade. If the two forces are themselves resolved, then it would be seen that the stern of the vessel is moved to starboard. Consequently, if the stern is moved to starboard, then the bow may be seen to move to port. The opposite will happen when the vessel is moving astern, the only difference being that the side component will be resolved with a sternway motion and the result will be that the stern cants to port, with the bow going to starboard (see Figure 9.5).

Securing the propeller is shown in Figure 9.6.

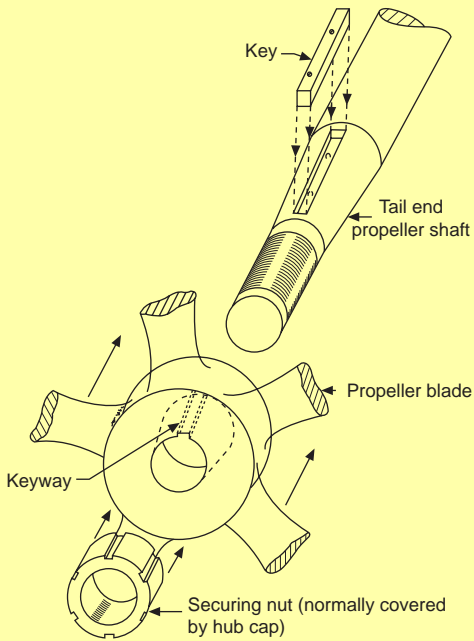

Figure 9.6 Method of securing conventional propeller.

Controllable Pitch Propeller

This is probably one of the most practical, and certainly most valuable, advances in the marine industry over the last 20 years (Figures 9.7 and 9.8). The advantages of the controllable pitch propeller over and above the conventional fixed propeller are as follows:

1. A reduction in fuel costs and consumption is achieved by the regular fixed turning speed of the shaft. The main machinery operates under optimum conditions per tonne of fuel burned.
2. Expensive diesel fuel is saved by the use of 'shaft alternators' linked to the constant speed rotating shaft. Auxiliary generators, though still carried, are not required for the normal loads that would be expected aboard a conventional vessel with a fixed propeller.
3. Should the propeller be damaged, spare propeller blades are carried and can be relatively easily fitted. Should only one blade be damaged, then the pitch of the propeller can be increased in order to return to port under the vessel's own power, though at a reduced speed.
4. A distinct ship-handling advantage is obtained by being able to stop in the water without having to stop main engines.
5. The need for compressors and for compressed air, for use in starting 'air bottles', is greatly reduced.
6. The watch officer gains more direct control over the vessel's speed for anti-collision purposes.

The advantages of the controllable pitch propeller system are now accepted, and one may wonder why more ships are not so fitted. The main reason is the very high cost of installation at the building stage, and the even higher cost of installing a CPP as a structural alteration to an existing vessel. A minimum shaft horsepower must also be present from the main machinery in order to obtain fuel economy and efficient running.

Manufacturers have accepted the needs of the industry by incorporating several features to improve the system.

Automatic disengaging of the propeller blades can now be achieved in some designs. This is especially desirable, for example, in small harbours, when the eddies in a constant rotating shaft may cause concern to small-boat owners or moored yachts near the stern.

Emergency over-ride controls may be included, and usually are, to enable the automation system to be by-passed and bring direct load on to the pitch actuator of the propeller.

Twin-screw Single Rudder Vessels

Twin-screw vessels are normally designed with their propellers equidistant from the fore and aft line. Usually both are outward turning, the starboard propeller being right-hand-fixed and the port-propeller left-hand fixed. Many modern vessels are now constructed with twin controllable pitch propellers, especially fast ferries and the like.

The twin-screw vessel is usually easier and simpler to handle than the conventional single-screw vessel. The transverse thrust on a single screw

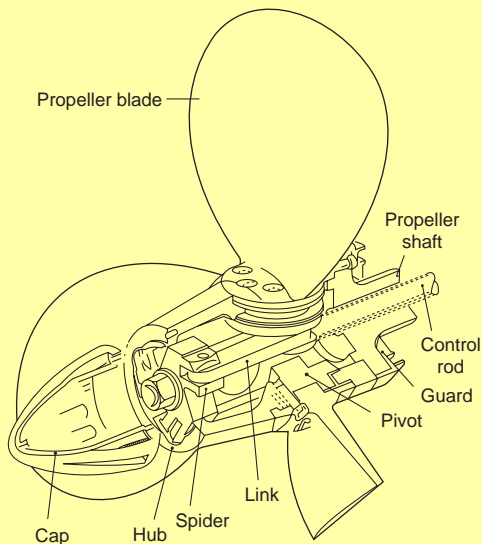

Figure 9.7 Controllable pitch propeller.

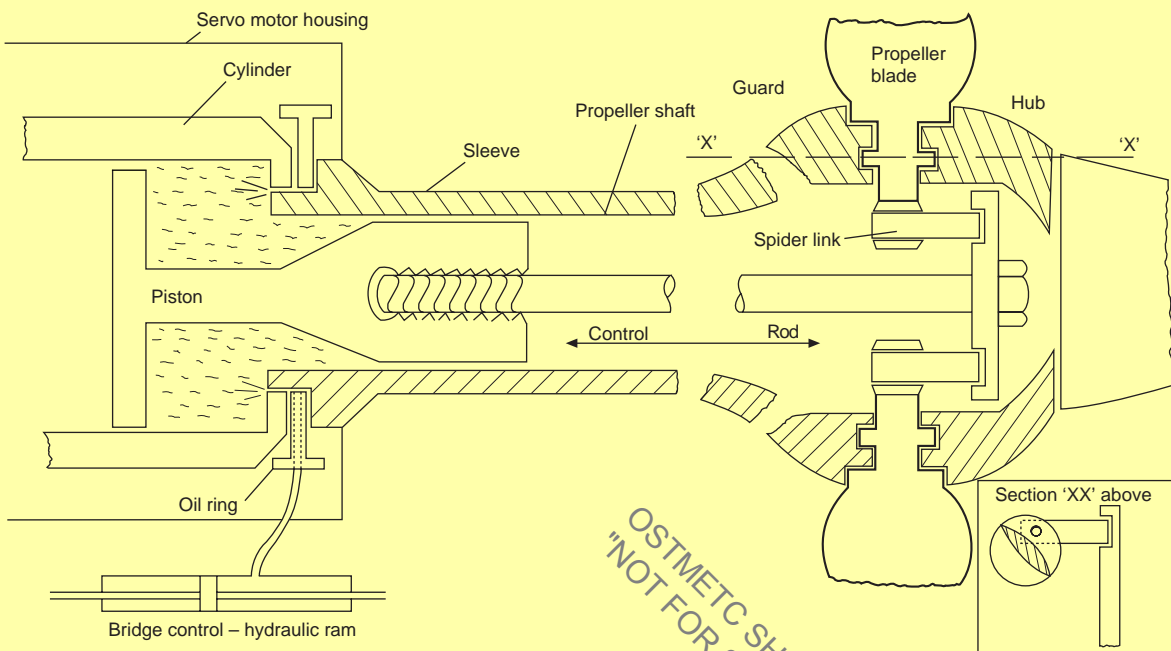

Figure 9.8 Controllable pitch propeller – working parts.

vessel strongly affects the steering capability, but with twin screws the forces tend to counteract each other, preventing the steering problems experienced by the single screw vessel (see Figure 9.9).

A distinct advantage of twin screws, apart from the increased speed created, is that if the steering gear breaks down, the vessel can still be steered by adjusting the engine revolutions on one or other of the propellers. When turning the vessel, for instance, one propeller can go ahead while the other is going astern (Figure 9.10).

Propeller Slip

When the vessel is moving ahead, the propeller exerts pressure on the water to create the forward motion. Propeller slip occurs because water is not a solid medium and there is some 'slip' related to it.

Slip may be considered as the difference between the speed of the vessel and the speed of the engine. It is always expressed as a percentage:

$$\text{Propeller slip} = \frac{\text{Actual forward speed}}{\text{Theoretical forward speed}} \text{ (per cent)}$$

The calculated value of slip will be increased when the wind and sea are ahead, and if the vessel has a fouled bottom. The differing values of slip are especially noticeable after a vessel has been cleaned in drydock.

Theoretically a vessel should never have a negative slip, but this may occur in one or more of the following conditions: a strong following sea, a following current or a strong following wind.

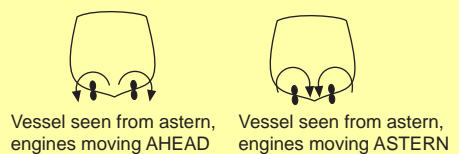

Figure 9.9 Twin-screw propulsion.

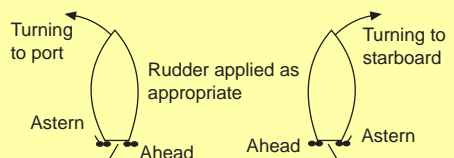

Figure 9.10 Steering by engines.

Example 1

During a 24-hour period of a voyage a ship's propeller shaft was observed to turn at 87 rpm. The pitch of the propeller was 3.8 m.

The observed ship's speed over the ground was 10 knots for the same 24-hour period. Calculate the value of the propeller slip during this period. (A nautical mile equals 1852 m.)

$$\text{Slip (per cent)} = \frac{\text{Engine distance} - \text{Ship's distance}}{\text{Engine distance}} \times 100$$

$$\text{Engine distance} = \frac{\text{Pitch} \times \text{rpm} \times 60 \times 24}{1852}$$

$$= \frac{3.8 \times 87 \times 60 \times 24}{1852}$$

$$= 257.054$$

$$\text{Ship's distance} = 24 \times 10$$

$$= 240$$

$$\text{Slip} = \frac{257.054 - 240}{257.054} \times 100$$

$$= + 6.9 \text{ per cent}$$

Example 2

A propeller has a pitch of 4.5 m. The ship steams for a period of 18 hours at 115 rpm and then steams for a further 6 hours at the reduced speed of 100 rpm. After the full 24-hour period the logged distance indicates 330 miles but the log is known to have a 2 per cent negative slip. Calculate the propeller slip (A nautical mile equals 1852 m.)

$$\text{Propeller slip (per cent)} = \frac{\text{Engine distance} - \text{Ship's distance}}{\text{Engine distance}} \times 100$$

(From the log)

$$\text{Ship's distance} = \left(\frac{330}{100} \times 2 \right) + 330$$

$$= 336.6 \text{ nautical miles.}$$

$$\text{Engine distance} = \frac{4.5 \times 115 \times 18 \times 60}{1852} + \frac{4.5 \times 100 \times 6 \times 60}{1852}$$

$$= 301.8 + 85.33$$

$$= 387.13 \text{ nautical miles}$$

$$\text{Propeller slip} = \frac{387.1 - 336.6}{387.1} \times 100$$

$$= \frac{50.5}{387.1} \times 100$$

$$= + 13.05 \text{ per cent}$$

TURNING CIRCLES

General Definitions

Advance

This is the forward motion of the ship from the moment that she starts the turn, i.e. the distance travelled by the vessel in the direction of the original course from starting the turn to completing the turn.

Diameters

The greatest diameter scribed by the vessel from starting the turn to completing the turn (ship's head through 180°) is the *tactical diameter*. The internal diameter of the turning circle where no allowance has been made for the decreasing curvature as experienced with the tactical diameter is the *final diameter*.

Transfer

This is defined by that distance which the vessel will move, perpendicular to the fore and aft line at the commencement of the turn. The total transverse movement lasts from the start of the turn to its completion, the defining limits being known as the transfer of the vessel when turning.

Advice for Helmsman and Officer of the Watch

1. A deeply laden vessel will experience little effect from wind or sea when turning, but a vessel in a light or ballasted condition will make considerable leeway, especially with strong winds.
2. When turning, the pivot point of the vessel is often situated well forward of the bridge and may produce the effect of the vessel turning at a faster rate than she actually is.
3. A vessel trimmed by the stern will steer more easily but the tactical diameter of the turn is increased.
4. A vessel trimmed by the head will decrease the diameter of the turning circle but will become difficult to steer.
5. If a vessel is carrying a list, the time taken to complete the turn will be subject to delay. A larger turn will be experienced when turning into the list.

Factors Affecting Turn

If the vessel is fitted with a right-hand fixed propeller, she would benefit from the transverse thrust effect, and her turning circle, in general, will be quicker and tighter when turning to port than to starboard. The following factors will affect the rate of turn and the size of turning circle:

1. Structural design and length of the vessel.
2. Draught and trim of vessel.
3. Size and motive power of main machinery.

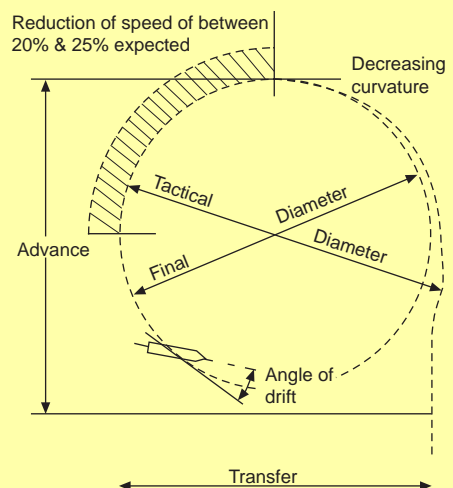

Figure 9.11 Turning circle.

27. New hull design has caused major changes to many marine aspects not least, ship handling and manoeuvring but also to rescue and survival recovery operations.



4. Distribution and stowage of cargo.
5. Even keel or carrying a list.
6. Position of turning in relation to the available depth of water.
7. Amount of rudder angle required to complete the turn.
8. External forces affecting the drift angle.

1. *Structural design and length.* The longer the ship generally, the greater the turning circle. The type of rudder and the resulting steering effect will decide the final diameter, with the clearance between rudder and hull having a major influence. The smaller the clearance between rudder and hull the more effective the turning action.
2. *Draught and trim.* The deeper a vessel lies in the water, the more sluggish will be her response to the helm. On the other hand, the superstructure of a vessel in a light condition and shallow in draught is considerably influenced by the wind.

The trim of a vessel will influence the size of the turning circle in such a way that it will decrease if the vessel is trimmed by the head. However, vessels normally trim by the stern for better steerage and improved headway and it would be unusual for a vessel to be trimmed in normal circumstances by the head.

3. *Motive power.* The relation between power and displacement will affect the turning circle performance of any vessel in the same way that a light speedboat has greater acceleration than a heavily laden ore carrier. It should be remembered that the rudder is only effective when there is a flow of water past it. The turning circle will therefore not increase by any considerable margin with an increase in speed, because the steering effect is increased over the same period. (The rudder steering effect will increase with the square of the flow of water past the rudder.)
4. *Distribution and stowage of cargo.* Generally this will not affect the turning circle in any way, but the vessel will respond more readily if loads are stowed amidships instead of at the extremities. Merchant

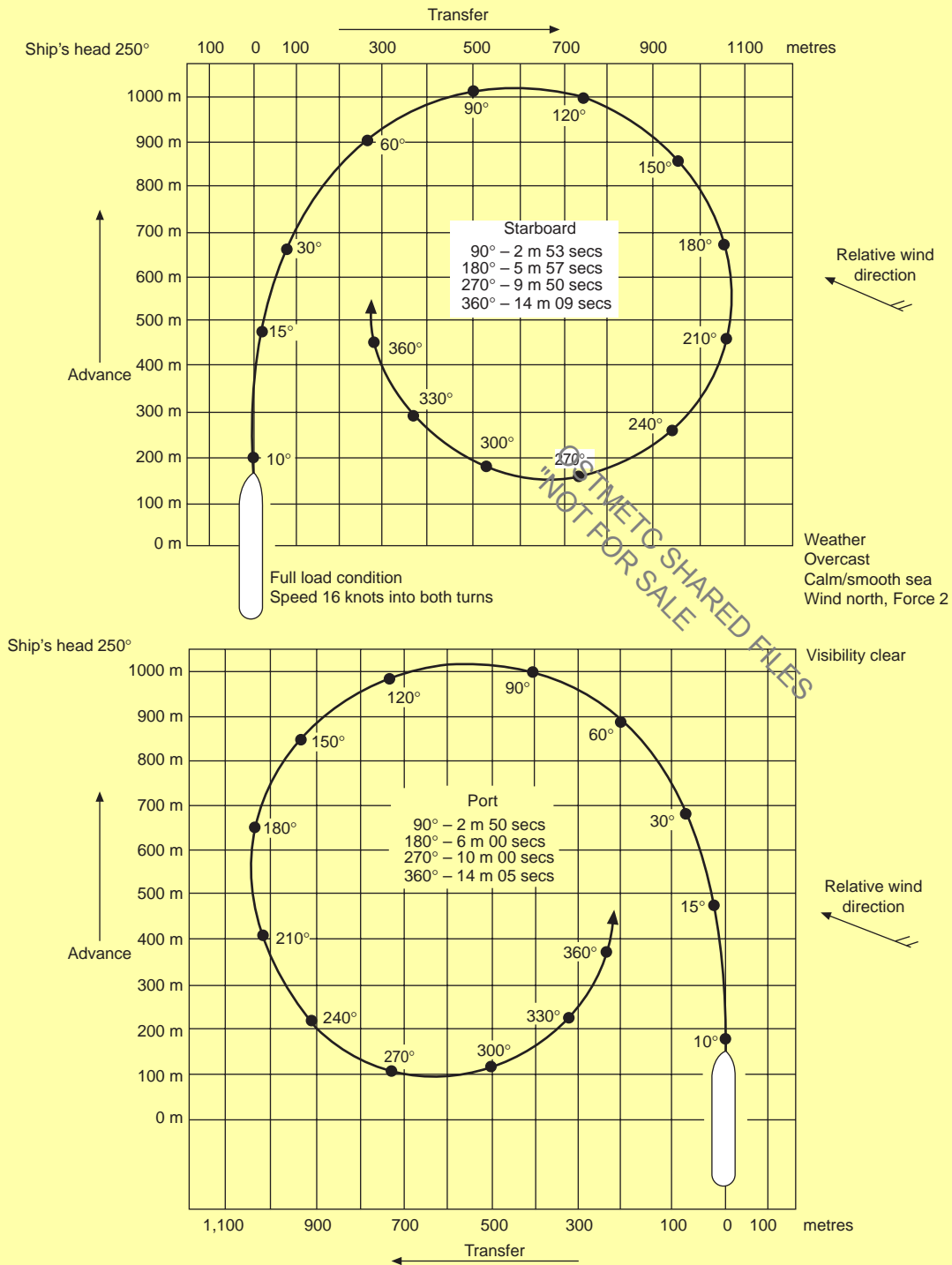

Figure 9.12 Turning circle of VLCC. Particulars of vessel: gross tonnage 133,035; net 108,853; dead weight 270,665; length OA 338.6 m; breadth 53.6 m; mould depth 26.4 m; load draught 20.6 m; main engine power 22,380 kW.

ship design tends to distribute weight throughout the vessel's length. The reader may be able to imagine a vessel loaded heavily fore and aft responding slowly and sluggishly to the helm.

5. *Even keel or listed over.* A new vessel when engaged on trials will be on an even keel when carrying out turning circles for recording the ship's data. This condition of even keel cannot, however, always be guaranteed once the vessel is commissioned and loaded. If a vessel is carrying a list, it can be expected to make a larger turning circle when turning towards the list, and vice-versa.
6. *Available depth of water.* The majority of vessels, depending on hull form, will experience greater resistance when navigating in shallow water. A form of interaction takes place between the hull and the sea bed which may result in the vessel yawing and becoming difficult to steer. She may take longer to respond to helm movement, probably increasing the advance of the turning circle, as well as increasing over the transfer. The corresponding final diameter will be increased retrospectively.
7. *Rudder angle.* Probably the most significant factor affecting the turning circle is the rudder angle. The optimum is one which will cause maximum turning effect without causing excessive drag.

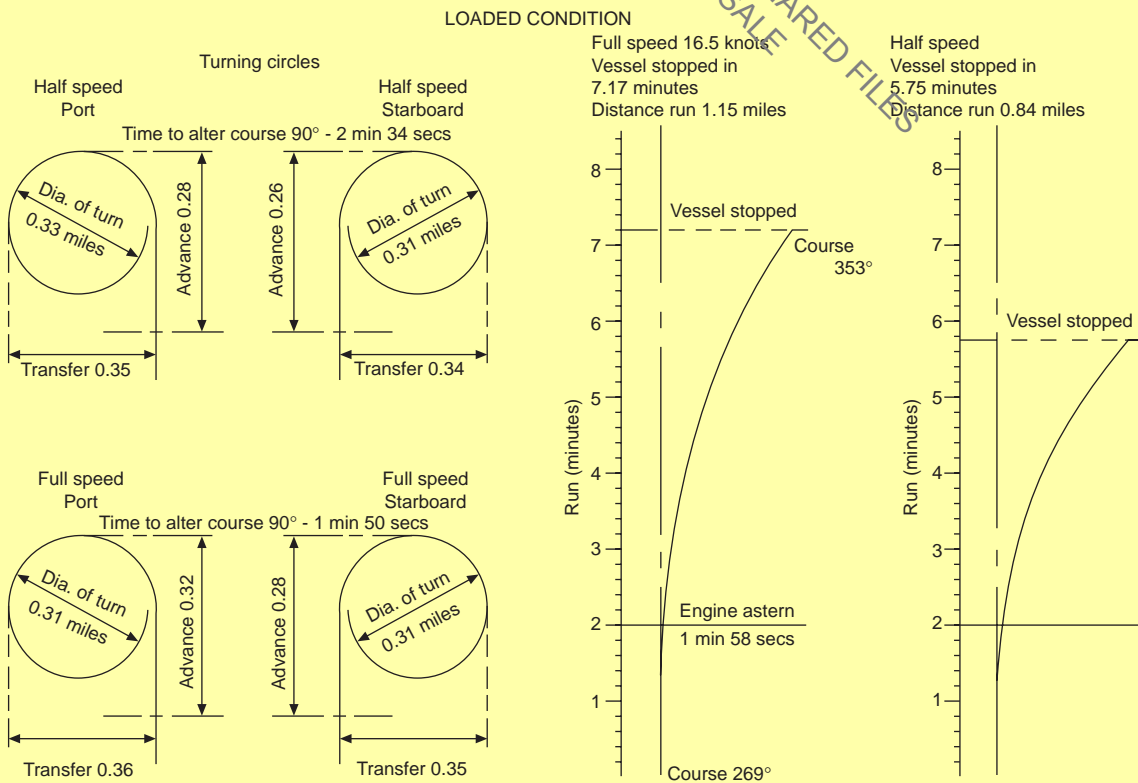

Figure 9.13 Turning circle of vessel with following particulars: gross tonnage 8243; net 4461; dead weight 13,548; 5 hatch general cargo; length OA 161 m; breadth 22.97 m; loaded draught 13.1 m; main engine power 8952 kW.

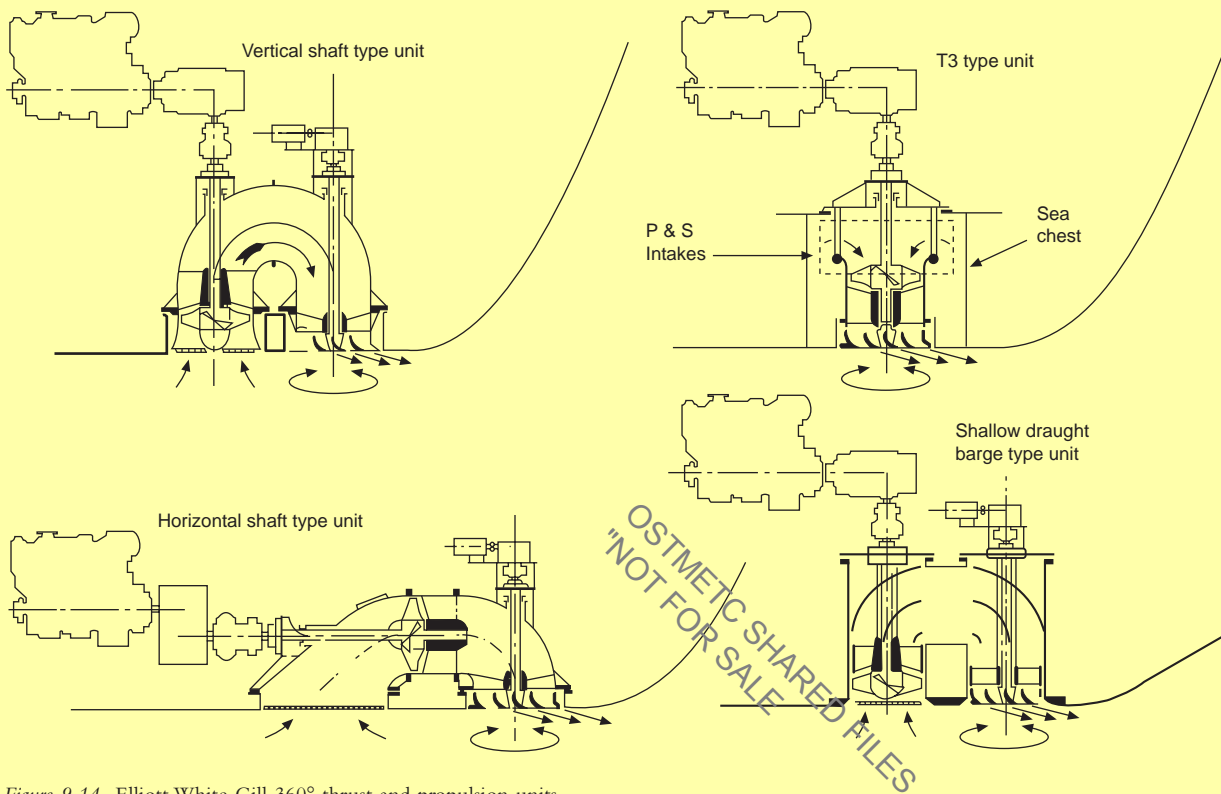

Figure 9.14 Elliott White Gill 360° thrust and propulsion units.

If a small rudder angle is employed, a large turning circle will result, with little loss of speed. However, when a large rudder angle is employed, then, although a tighter turning circle may be experienced, this will be accompanied by a loss of speed.

8. *Drift angle and influencing forces.* When a vessel responds to helm movement, it is normal for the stern of the vessel to traverse in opposing motion. Although the bow movement is what is desired, the resultant motion of the vessel is one of crabbing in a sideways direction, at an angle of drift.

When completing a turning circle, because of this angle of drift, the stern quarters are outside the turning circle area while the bow area is inside the turning circle. Studies have shown that the 'pivoting point' of the vessel in most cases describes the circumference of the turning circle.

BOW/STERN THRUSTER UNITS

Elliott White Gill 360° Thrust and Propulsion Units

Over the last twenty years thrust units have proved themselves in all aspects of ship-handling. Advances in design, power and control have all led to the development of bigger thrusters and better performance.

SHIPHANDLING

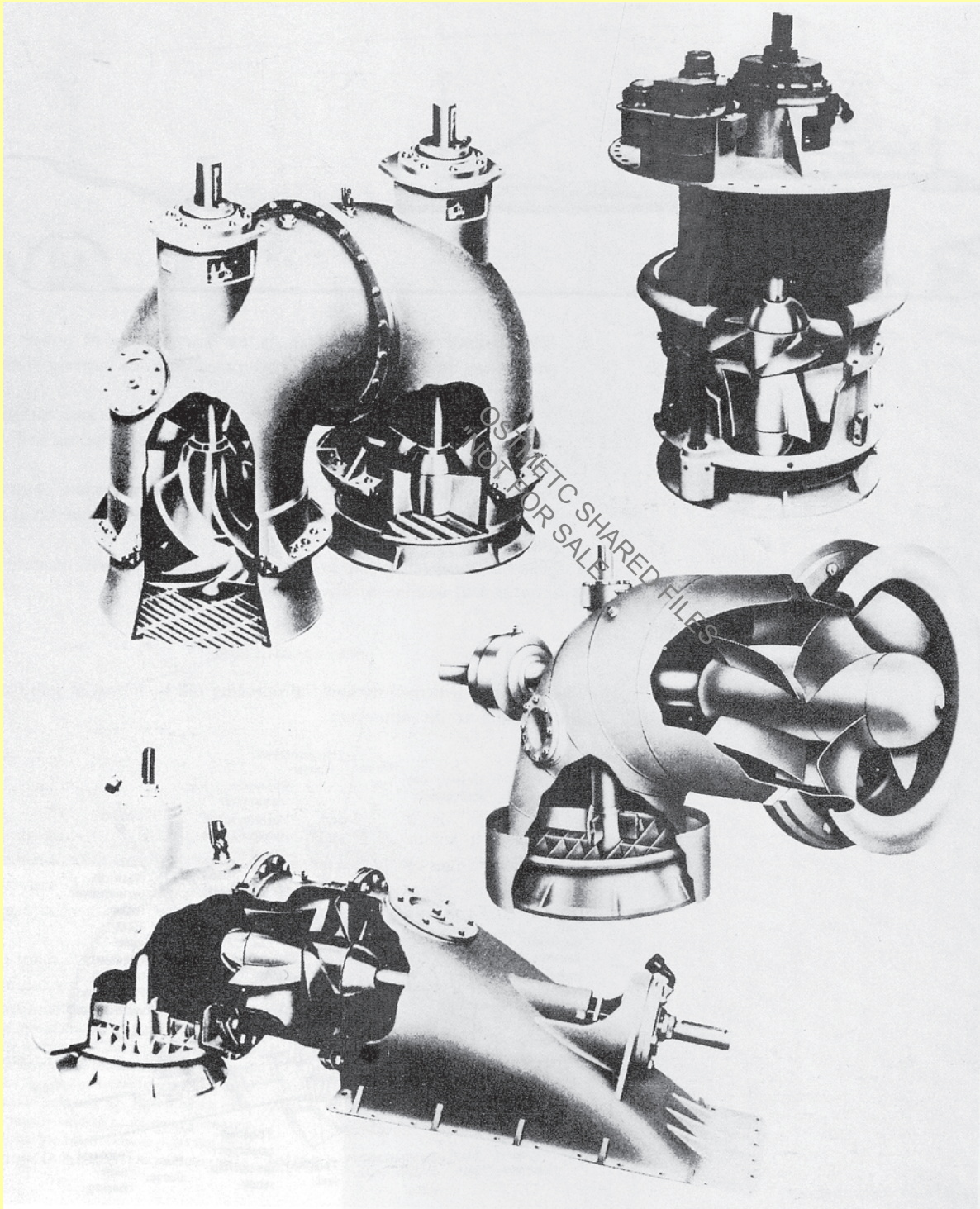

28. Bow thrust units as manufactured by Elliott Turbomachinery Ltd. These thrusters provide steering control without the use of rudders and main engines. Four models are available, capable of delivering thrusts of up to 17,000 kg. They are, shown clockwise from upper left, the Vertical Shaft, the T-3, the Cross Shaft and the Horizontal Shaft designs.

The Elliott White Gill 360° thruster unit (Figure 9.14) has some distinct advantages over the conventional 'tunnel thruster'. Not only can the force of the thrust be directed as the operator desires but with its location totally submerged all the time there is little chance of damage from surface obstructions.

The position of installation is so far beneath the water surface that the performance is not impaired by heavy weather. Pitching or heavy rolling have little or no effect as the intakes rarely break surface, if at all. Limited maintenance is required, with the unit being readily accessible from within the vessel. No part of the unit projects beyond the lines of the hull.

Bow thruster units are further illustrated in Plate 28.

Elliott White Gill 360° Trainable Thrust Units

The main ship-handling features of the 360° trainable thruster (Figure 9.15) are:

1. The thruster may be used as an auxiliary means of power or propulsion, being employed for both propulsion and steering of the vessel.
2. It is capable of turning a vessel in its own length and turning 'broadside' on without resorting to the use of main engines and/or rudder.
3. Remote control of thruster unit is achieved from a main control bridge panel. Additional bridge wing control panels may be fitted as required.
4. The thrust capacity of up to 17 tonnes can hold the vessel on station even in bad weather or heavy sea conditions.

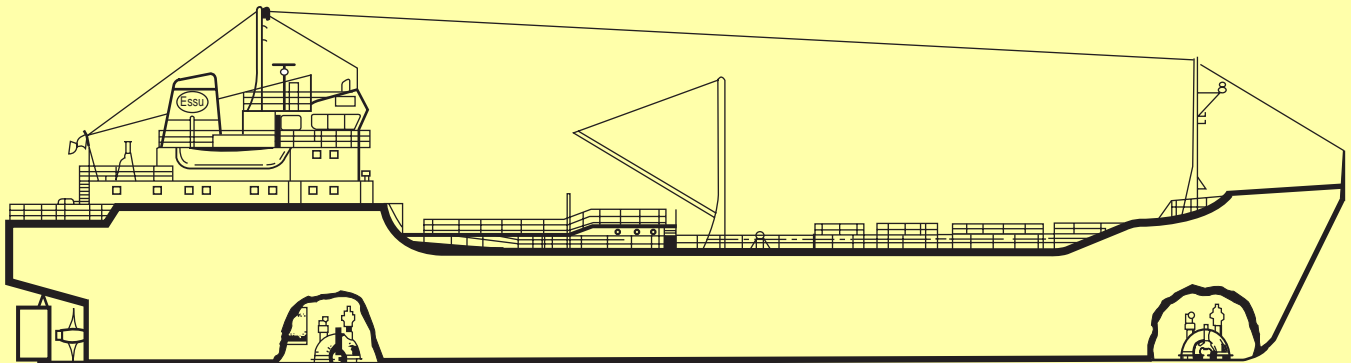

Figure 9.15 Elliott White Gill 360° trainable thrust units.

FIN STABILISERS

There are two principal methods of reducing roll by means of stabilisation available to the shipowner:

- (a) Active fin – folding (Figures 9.16 and 9.17) or retractable type.
- (b) Free surface tanks.

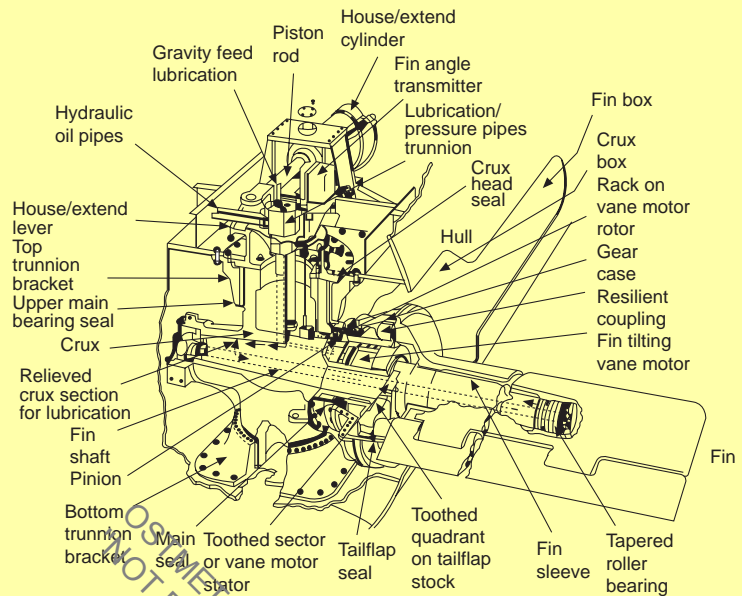

Figure 9.16 Fin stabilisers.

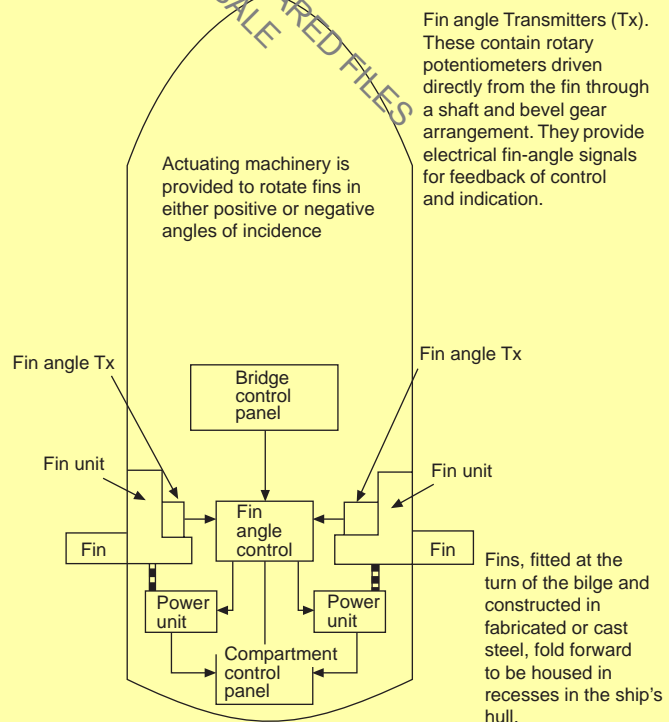

Figure 9.17 Folding fin stabiliser unit.

Both systems have their merits, but the fin types would appear to be unrivalled when fitted to vessels engaged at speeds in excess of 15 knots. Should the vessel be operating at low speeds or at anchor in an exposed

position, then a free surface tank system may be better suited for the nature of work.

MANOEUVRING WITH MOORING LINES

The main function of mooring lines, be they wire or fibre ropes, is to retain the vessel in position. However, there are times when they may be used in the turning or manoeuvring of the vessel, as when entering a dock or coming off quays (see Figures 9.18 and 9.19).

FAIRLEADS

The roller fairlead is often encountered as a double or even treble lead, but is also found as a single lead on a stand or pedestal (Figure 9.20). It is in common use aboard a great many modern vessels, where it is generally referred too as an 'old man' or a 'dead man' because of its static pose. It has proved its usefulness in mooring operations for altering the lead of a rope or wire through very sharp angles.

Maintenance should be on a regular basis with regard to greasing and oiling about the axis. The pedestal should be painted at regular intervals to prevent corrosion. Should a lead of this type become seized it is normal to soak the moving parts in release oil and then attempt to free the roller lead by use of a mooring rope to the warping drum end, so creating a friction drive.

Universal Multi-angled Fairlead

This fairlead (Figure 9.21) consists of two pairs of axial bearing rollers, one pair in the vertical plane and the other pair in the horizontal. The main advantage of this type of lead is that it provides a very wide angular range not only in the horizontal and vertical planes but also in any oblique plane.

The main disadvantage of the lead is that it requires regular maintenance in the way of periodic greasing through grease nipples at each end of the rollers. When compared with the panama lead, the rollers respond when mooring lines are under tension, so that friction is reduced, whereas the panama lead has no moving parts and friction may cause limited damage.

Universal leads are regularly found on the quarter and shoulder areas of the vessel for the multiple use of spring or head and stern lines.

Panama Lead

This type of lead is very common aboard modern vessels.

It may be a free standing lead, as shown in Figure 9.22, in which case the underdeck area is strengthened, or it may be set into bulwarks and strengthened by a doubling plate. The lead is one favoured by seafarers because the rope or wire cannot jump accidentally when under weight.

BOLLARDS (BITTS)

The term 'bollard' is usually applied to a mooring post found on the quayside and 'bitts' to the twin posts found on ships (Figure 9.23).

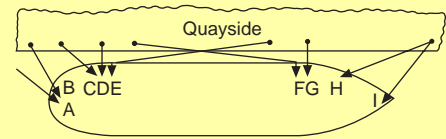

Key	A, B, C	Sternlines
	D	Breastline
	E	After spring
	F	Forward spring
	G	Breastline
	H, I	Headlines

Figure 9.18 Example of moorings used to secure vessel to quay.

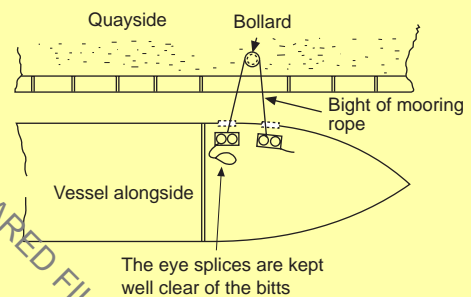

OSTIMEG SHARED FILES

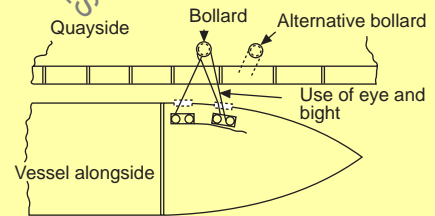

Figure 9.19 Mooring rope used as a bight (above) and as an eye and a bight (below).

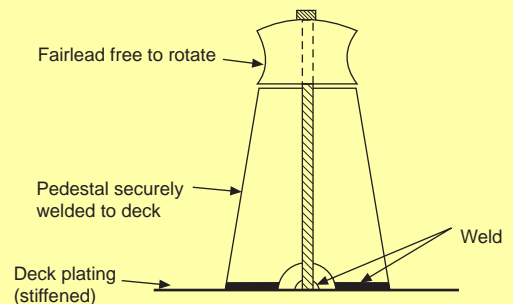

Figure 9.20 Roller fairlead.

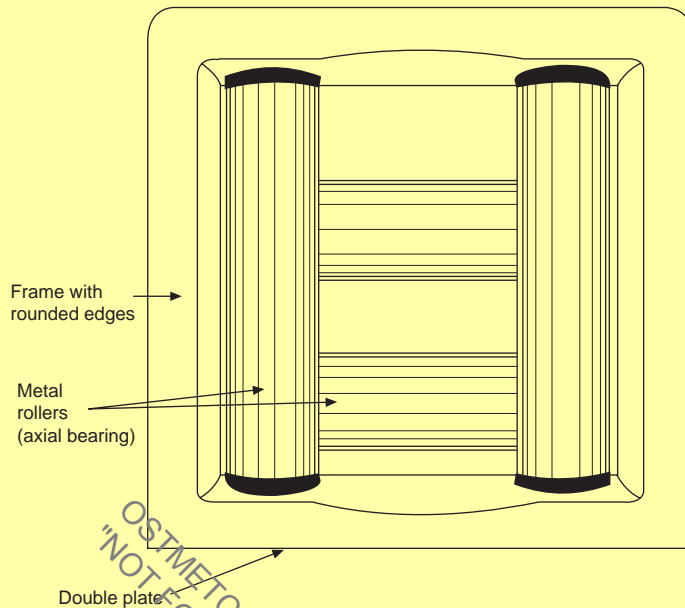

Figure 9.21 Universal multi-angled fairlead.

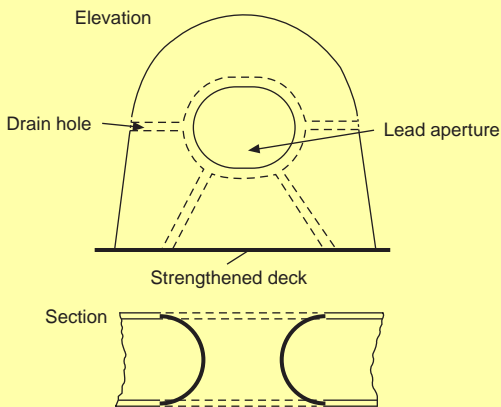

Figure 9.22 Panama lead.

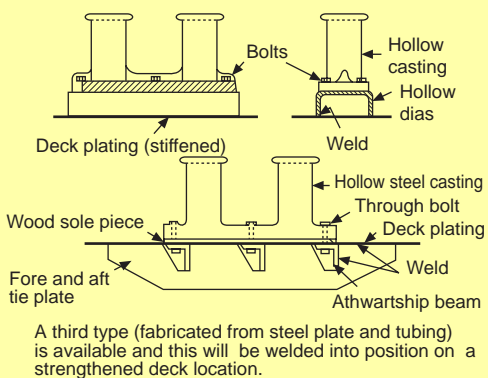

Figure 9.23 Bollards and bitts.

The purpose of the slip wire is to enable the vessel to let herself go, at any time, without being dependent on the port's linesmen to clear lines from bollards. It is generally always the last line to let go. In some circumstances a slip rope may be used (see Figure 9.24).

Slip wires tend to run easily when letting go and heaving taut, but the wire is heavy and often difficult to handle. A strong messenger must be employed to heave the eye back aboard when rigging, because the wire will not float as a rope may, and there may be a long drift between the bow or stern and the bollard buoy.

Slip ropes are easier to handle and manipulate through the ring of a mooring buoy, but they are bulky and slow in running because of surface friction between the rope and buoy ring. They generally float on the surface when going out to the buoy and when being heaved back aboard, this fact considerably reduces the weight on the messenger.

Whether a wire or rope is to be used, a prudent seaman will always seize the eye of the slip to allow clear passage through the ring of a mooring buoy.

Operation

Arrange the slip wire in long flakes down the deck length, then pass the eye down into the mooring boat. Additional slack on the wire should be given to the boat and coiled down on the boat's bottom boards. This provides the boat handler with slack to ease the weight, should the slip become snagged aboard. Pass a messenger into the mooring boat with the slip wire, but do not make the messenger fast to the slip wire at this stage.

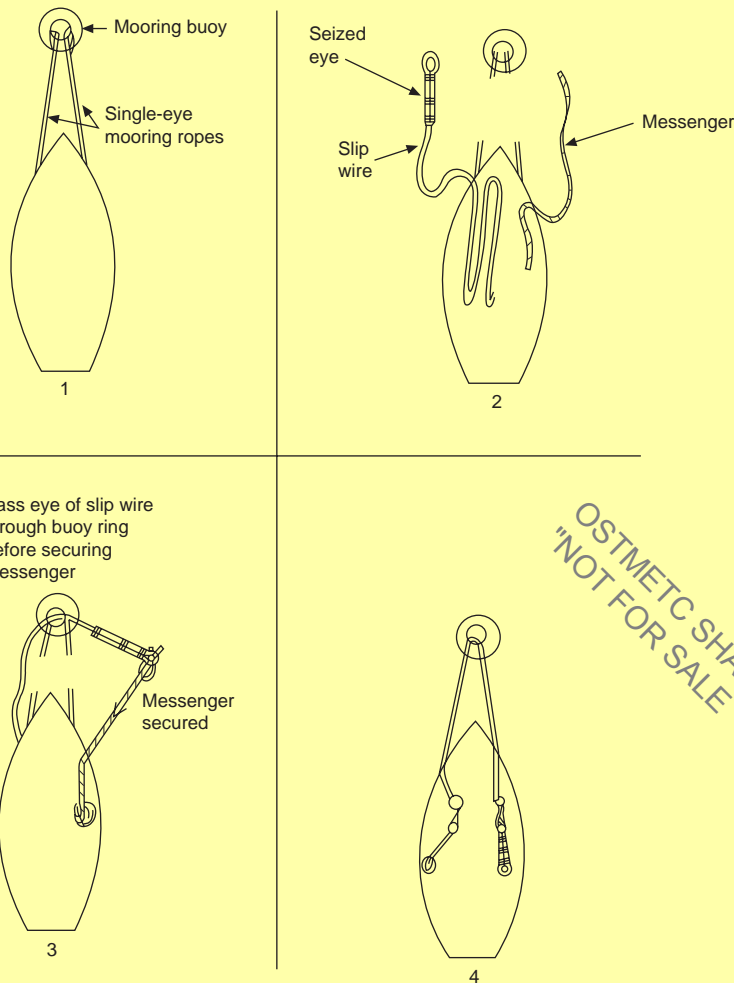

Figure 9.24 Rigging of slip wires.

A port mooring boat will be required for this operation, together with a lifejacket for the man engaged in buoy jumping and dipping the lines through the ring of the buoy.

1. Secure the forward or after end to the buoy in order to steady the vessel before passing the slip wire.
2. Prepare the slip wire beforehand by seizing the eye of the wire to enable it to pass through the ring of the buoy. Flake a messenger to the mooring boat with the slip.
3. Dip the slip wire through the ring of the buoy and secure the messenger to it. Once the small boat is clear, signal the vessel to heave the slip wire aboard, via the messenger.
4. Once the slip wire is aboard, release the messenger and turn up the slip wire on the bollards. Do not place eyes over bits, as this may restrict letting go when weight is on the wire.

As the mooring boat travels towards the buoy, pay out both slip wire and messenger. A man wearing a lifejacket should then 'jump the buoy', pass the seized end of the slip through the ring, then secure the messenger to the small part of the eye of the slip wire. The messenger should never be passed through the ring of the buoy first, for this may cause the hitch to jam in the ring of the buoy when heaving back aboard. Signal to the officer in charge aboard the vessel to heave away on the messenger and bring the slip wire back aboard. Detach the messenger and turn up both parts of the slip wire in 'figure eights' on the bits. Do not put the eyes of the slip on the bits, as this would make letting go difficult if weight is on the wire.

BERTHING

Let us assume that no tugs are available and that the ship has a right-hand fixed propeller (see Figures 9.25 and 9.26).

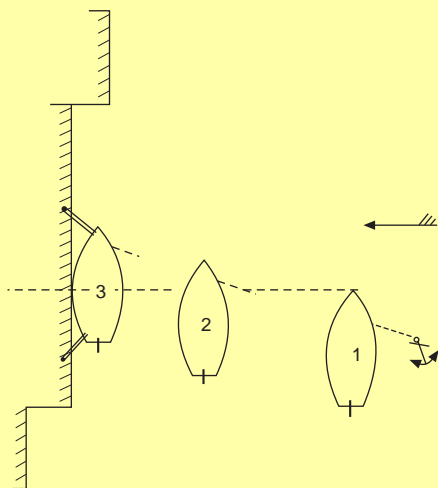

Figure 9.25 Berthing, wind onshore, tidal conditions calm.

1. Stop the vessel over the ground in a position with the ship's bow approximately level with the middle of the berth. Let go offshore anchor.
2. Control the rate of approach of the vessel towards the berth by ahead movements on main engines, checking and easing out anchor cable as required. Try and keep the vessel parallel to the berth.
3. Check cable within heaving line distance of the berth. Make fast fore and aft. Slack down cable when alongside.

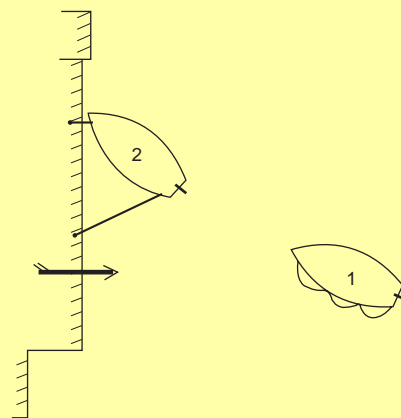

Figure 9.26 Berthing, wind offshore, tidal conditions calm.

1. Approach berth at a wide angle to reduce wind effect and prevent the bow from paying off.
2. Slowly approach berth and maintain position over ground.
3. Pass head line and stern line together from the bow area.
4. Stay dead slow astern on main engines, ease head line and at the same time take up the weight and any slack on the stern line. Draw the vessel alongside and secure. Depending on the strength of the wind, it would be advisable to secure a breast line forward as well as additional lines fore and aft as soon as practicable.

CLEARING A BERTH

Let us assume that no tugs are available and that the ship has a right-hand fixed propeller (see Figures 9.27 to 9.30).

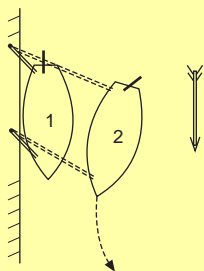

Figure 9.27(a) Clearing a berth, wind and tide astern.

1. Single up to stern line and forward spring.
2. Main engine astern, ease out on stern line until stern is well clear of quay.
3. Let go and take in stern line. Let go forward.
4. When well clear of quay, stop main engine. Put rudder to port, and go ahead on main engine.

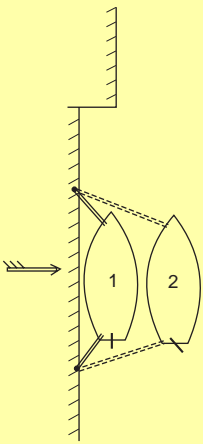

Figure 9.27(b) Clearing a berth, no tugs available, right-hand fixed propeller.

1. Single up to a head line and stern line.
2. Let vessel blow off the quay: keeping the vessel parallel to the quay by checking and controlling lines forward and aft.
3. When clear of the quay, let go fore and aft lines. Half ahead followed by full ahead on main engines if circumstances permit. Rudder applied as appropriate.

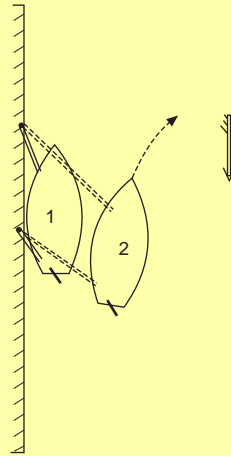

Figure 9.28 Clearing a berth, wind and tide ahead.

1. Single up to a head line and aft spring.
2. Ease away head line, rudder to starboard. With the tidal effect between the bow and the quayside the ship's bow should pay off.
3. Ease out on head line, slow ahead on main engines, take in head line and pick up slack on aft spring. Let go and take in aft spring. Use engine and rudder as appropriate.

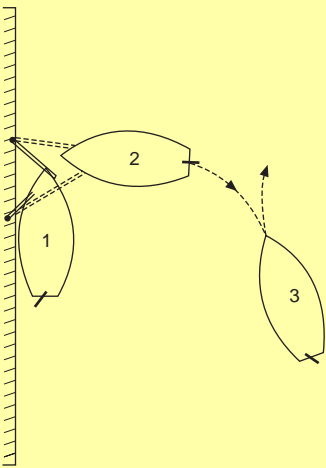

Figure 9.29 Clearing a berth, port side to, no wind or tide.

1. Single up forward to an offshore head line and forward spring.
2. Keeping the weight on the forward spring, heave on the head line in order to cant the stern away from the quay wall. The stern will make a more acute angle with the quay if the main engine is ordered 'dead' slow ahead and the rudder put hard to port. Care should be taken to avoid putting the stem against the quay wall, especially if the vessel is of a 'soft nose' construction. Let go in the forepart.
3. Put main engines astern and allow the vessel to gather sternway to clear berth.

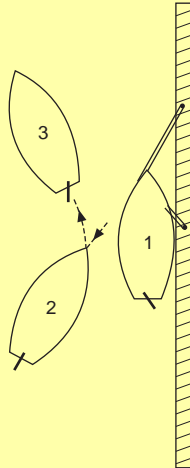
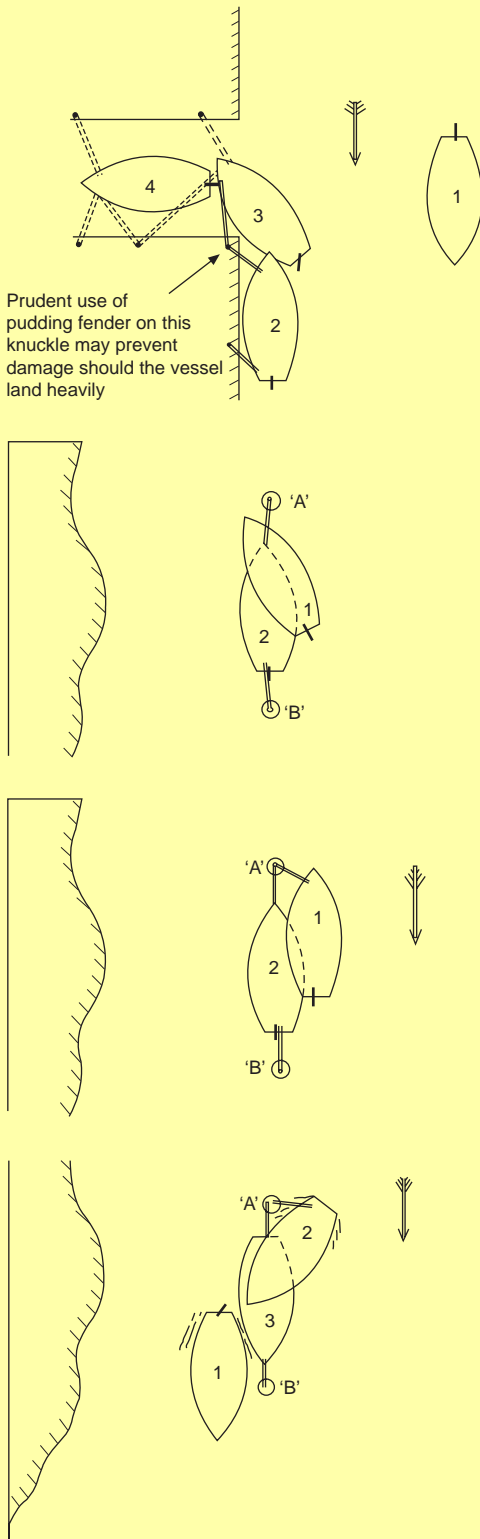

Figure 9.30 Clearing a berth, starboard side to, no wind or tide.

1. Single up forward to an offshore head line and forward spring.
2. Heave on the head line to bring the stern away from the quay wall. It may be necessary to double up the forward spring with the intention of using an ahead engine movement, allowing the spring to take the full weight, and effectively throwing the stern out from the quay. Let go smartly forward, main engines astern. When vessel gathers sternway, stop.
3. When clear forward, put rudder hard aport, and main engine full ahead.



ENTERING DOCK

No tugs are available and the ship has a right-hand fixed propeller (see Figure 9.31).

Figure 9.31 Entering dock, wind and tide astern.

1. The vessel should turn 'short round' (Figure 9.38) or snub round with use of starboard anchor. The ship will then be in a position of stemming the wind and tide and should manoeuvre to land 'port side to' alongside the berth below the dock.
2. Secure the vessel by head lines and aft spring to counter tide effect and keep her alongside.
3. Put main engines slow ahead to bring the 'knuckle' of the dock entrance midships on the vessel's port side. Pass a second head line from the starboard bow across the dock entrance to the far side. Take the weight on this head line. Let go aft spring. As the vessel comes up to the knuckle, ease the port head line until the ship's head is in the lock, then heave on the port head line to bring ship parallel to sides of lock.
4. Carry up head lines alternately from each bow. Send out stern line and forward spring once the vessel is inside the dock. Stop main engines and check ahead motion as appropriate.

SECURING TO BUOYS

No tugs are available and the ship has a right-hand fixed propeller (see Figures 9.32 to 9.35).

Figure 9.32 Securing to buoys, no wind or tide.

1. Approach the buoy 'A' slowly, with the buoy at a fine angle on the starboard bow, to allow for transverse thrust when going astern.
2. Stop the vessel over the ground and pass head and then stern lines. Align vessel between buoys 'A' and 'B' by use of moorings, and secure fore and aft.

Figure 9.33 Securing to buoys, wind and tide ahead.

1. The vessel should stem the tide and manoeuvre to a position with buoy 'A' just off the port bow. It may be necessary for the vessel to turn short round or snub round on an anchor before stemming the tide. Adjust main engine speed so that the vessel stops over the ground. Pass head line.
2. Although an astern movement of main engines would cause the bow to move to port, if required, holding on to the head line would achieve the same objective, by allowing the tide/current to effect the desired movement from position '1' to position '2'. Pass stern line once vessel is aligned between the two buoys 'A' and 'B'.

Figure 9.34 Securing to buoys, wind and tide astern.

1. Vessel under sternway, stern of the vessel seeking the eye of the wind. Use of rudder may assist to bring buoy 'A' on to the starboard quarter.
2. Run stern line from starboard quarter and make fast.
3. The vessel could expect to be moved by wind and tide to a position between the two buoys. The vessel may then be secured forward by head lines to buoy 'B'.
4. The success of this manoeuvre will, of course, depend on the strength of wind and tide. It might be necessary to turn the ship around to stem wind and tide, or, if the ship is to lie in the direction shown, it might be necessary to turn the ship and secure the bow to the other buoy shown and allow her to swing with the change of tide.

Care should be taken that any stern lines are kept clear of the propeller when the vessel is navigating stern first.

MOORING

The term mooring is used in conjunction with the securing of the vessel, either by two anchors or to a mooring buoy. The term is often used when vessels are moored to a jetty or quay by means of mooring ropes (Plate 29). The term may be considered, therefore, to be rather a loose one, applying to several methods of securing a ship. Most seafarers consider it to mean 'mooring with two anchors', in the form of a running moor, standing moor or open moor.

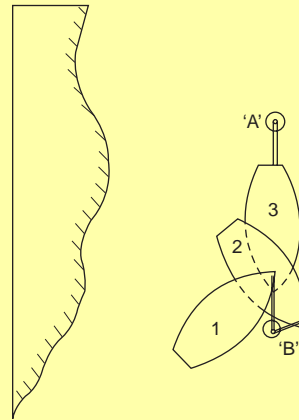

Figure 9.35 Securing to buoys, no wind or tide.

1. Approach buoy 'B' at a fine angle on the starboard bow. Pass head line and overrun the buoy about a third of the vessel's length from the bow. Hold on to the head line to check the vessel's headway. Allow the head line to act as a spring.
2. Rudder hard a-starboard, main engines ahead to turn the vessel about buoy 'B'.

Astern movement on engines will cause the port quarter to close towards buoy 'A'. This motion will further be assisted by the transverse thrust effect of the propeller. When the vessel is aligned between buoys, secure fore and aft.

LETTING GO FROM BUOYS

No tugs are available and the ship has a right-hand fixed propeller (see Figures 9.36 and 9.37).

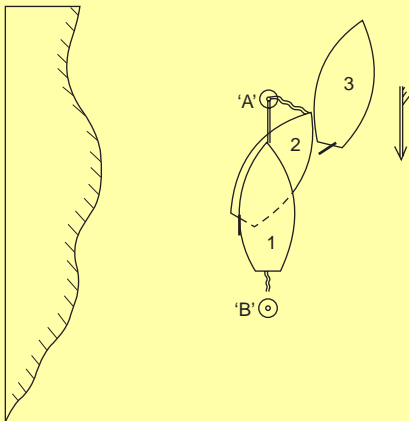

Figure 9.36 Letting go from buoys wind and tide ahead.

1. Let go stern line from buoy 'B'. When clear aft, apply starboard helm and go dead slow ahead on main engines.
2. As the vessel's bow moves to starboard, ease the head line. When clear of buoy 'A', let the head line go forward.
3. Main engines ahead, port rudder.

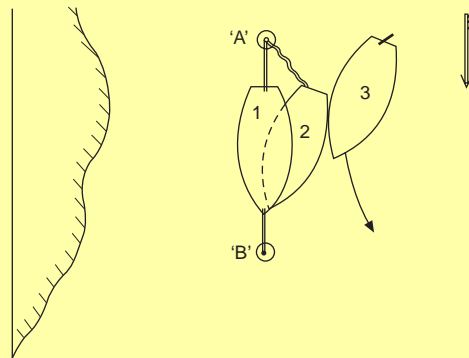

Figure 9.37 Letting go from buoys, wind and tide astern.

1. Slack stern line to see if the vessel will 'cant' away from buoy 'A'.
 2. If the vessel cants, let go head line, with main engines half astern. Port helm and allow vessel to gather sternway.
 3. When the vessel clears buoy 'A', let go stern line. Main engines ahead once stern line is clear of propeller, helm hard a-port.
- If the vessel will not 'cant', let go the head line and heave the vessel close up to buoy 'A'; put rudder hard a-port, let go aft, with main engines full ahead.
- Once headway is gathered, make sharp helm movement to hard a-starboard to throw the stern clear of the buoy.

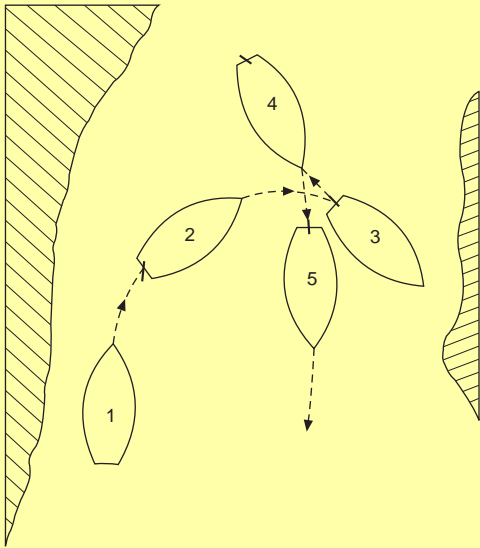

Figure 9.38 Turning a vessel short round.

The vessel is equipped with a right-hand fixed propeller, and, when turning 'short round', she would turn more easily to starboard than to port.

1. Start the manoeuvre from the port side of the channel to provide the maximum distance for the headreach movement of the vessel.
2. Rudder hard a-starboard, main engines full ahead. Stop engines. Do not allow the vessel to gather too much headway.
3. Rudder midships, main engines full astern.
4. As sternway is gathered, the bow of the vessel will cant to starboard while the port quarter will move in opposition, owing to the effects of the transverse thrust. Stop engines.
5. Rudder to starboard, engines ahead.

29. Vessel moored alongside a quay, secured by two head lines and a rope spring led aft from the starboard shoulder. The port anchor, having been let go during the berthing operation, has been left with the cable in the 'up and down' position for the purpose of heaving the vessel off the berth when letting go. Panama leads are clearly visible, one of them a centre lead. Triple roller fairleads are to be seen on either bow.

TURNING VESSEL SHORT ROUND

The ship has a right-hand fixed propeller (see Figure 9.38).

Running Moor

In all ship-handling situations the vessel should stem the tide if control is to be maintained. The running moor operation (Figure 9.39) is no exception to this rule, and should the tidal stream be astern of the vessel, then she should be manoeuvred to stem the tide, either by turning short round or snubbing round on an anchor. This will not always be possible however, and the running moor may have to be made with the tide. A running moor procedure is as follows:

1. Speed over the ground should be 4–5 knots, preferred depth of water being dependent on draught, and good holding ground chosen if possible. Let go the weather anchor, so that the vessel will be blown down from the anchor cable before she reaches the desired position.
2. Continue to make headway, paying out the cable of the anchor which has been let go. Continue to pay out the cable up to eight or nine shackles, depending on the amount of cable carried aboard and the depth of water. The vessel will overrun the desired mooring position.
3. The vessel should start to drop astern as the engines are stopped. Let go the lee anchor and pay out the cable. Start heaving away on the weather anchor cable to bring the vessel up between the two anchors. The vessel may require an astern movement on the engines to begin drawing astern.

In comparison with the standing moor the ship's machinery is running and operational throughout the manoeuvre. In the standing moor the vessel's machinery could well be out of action, standing still, while the vessel drops astern with the tidal stream.

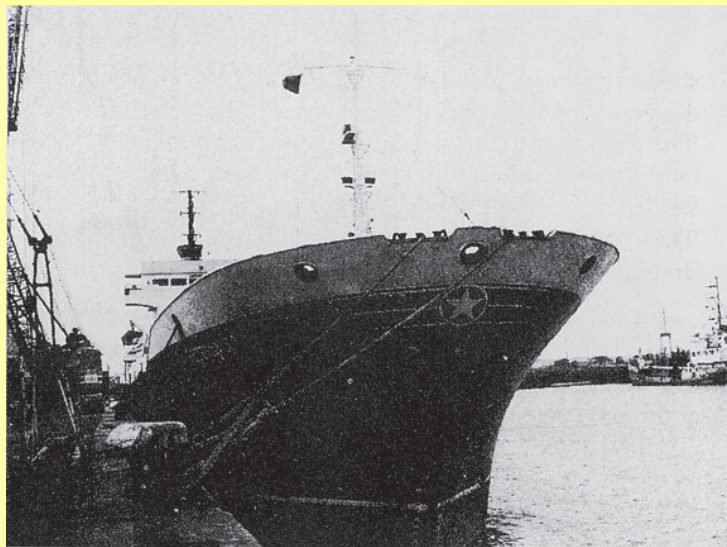

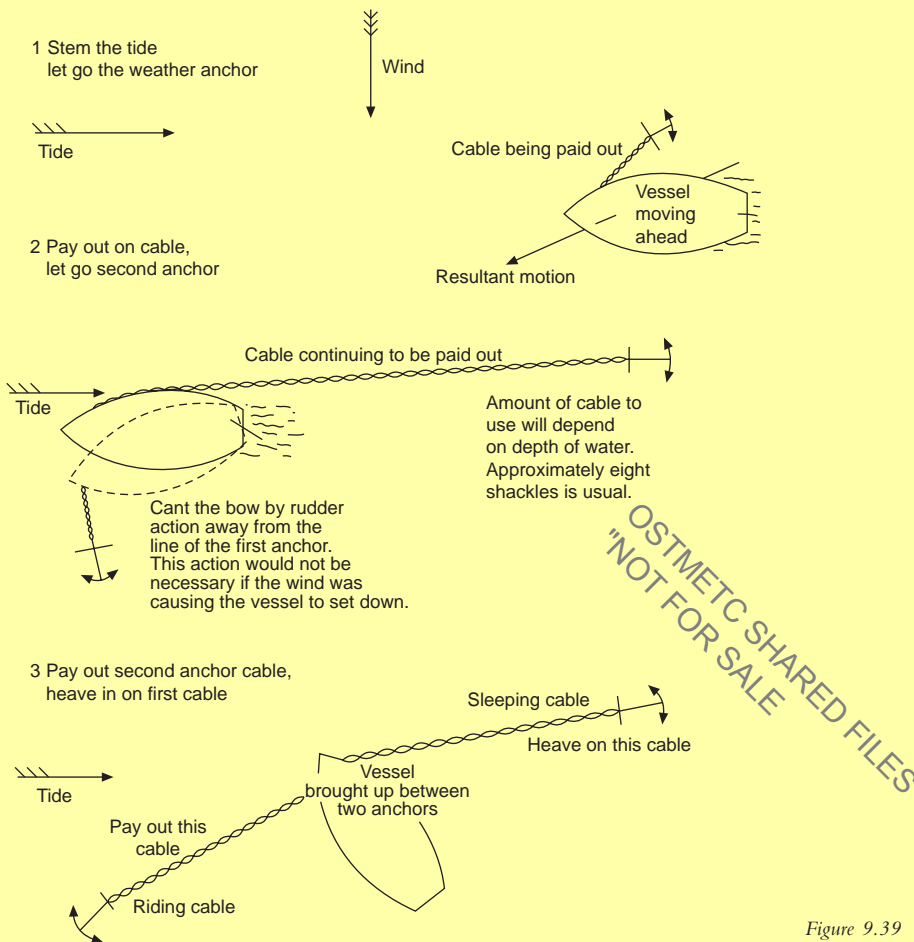

Figure 9.39 Running moor.

Standing Moor

The vessel must stem the tide, in order to retain control of the operation (Figure 9.40), which proceeds as follows:

1. The vessel should be head to tide, stopped over the ground. Sternway should be gathered either by the tidal stream or operating astern propulsion. Let go the lee anchor (riding cable) and allow the vessel to drop astern. Pay out the anchor cable as sternway is gathered, up to 8–9 shackles, depending on the amount of cable carried aboard and the depth of water.
2. Take the sternway off the vessel by use of engines ahead and checking on the weight of the cable. Order maximum helm away from the released anchor, and engines ahead to cant the vessel before letting go the weather anchor (sleeping cable). The mariner should continue to use engines ahead or astern as necessary to ease the weight on the windlass as the vessel heaves on the riding cable.

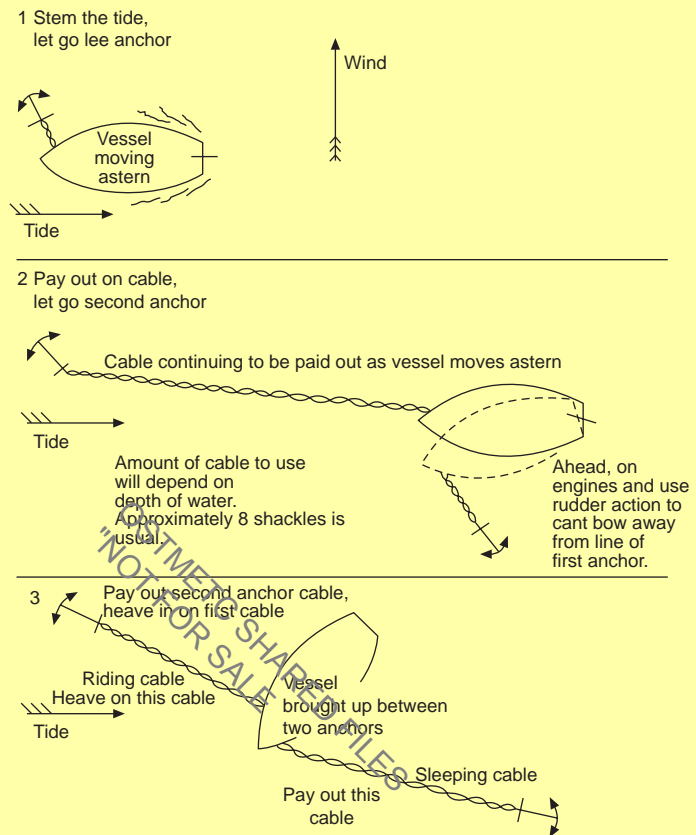

Figure 9.40 Standing moor.

3. Continue to heave on the riding cable and pay out the sleeping cable until the vessel is brought up between the two anchors.

A standing moor is sometimes preferred to a running moor when the tidal stream is very strong. The standing moor in theory could be carried out by just allowing the tidal stream and the windlass to do the work.

The main danger of mooring with two anchors is the possibility of causing a foul hawse when the vessel swings with the turn of the tide. To reduce this most undesirable condition the Royal Navy tends to use a mooring swivel, joining the two cables. Merchant vessels would not generally carry such a swivel, unless it is intended to secure the vessel to a semi-permanent mooring over an indefinite period of time.

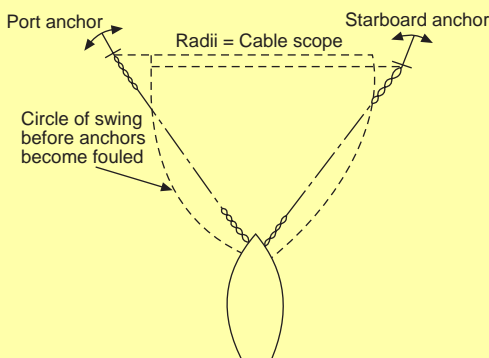

Figure 9.41 Open moor.

OPEN MOOR

The open moor (Figure 9.41) is used extensively when additional holding power is required. It would be employed when a single anchor would not provide enough weight to hold the vessel and prevent the ship from dragging.

Possibly the best method of approach is to stem the current and/or head the wind, and position the vessel to let go the windward anchor.

Once this first anchor has been 'let go' pay out on the cable with simultaneous 'ahead movements on engines' to manoeuvre the vessel towards a position of letting go the second anchor. Extensive use of rudder and engines may be required to achieve this second desired position.

Once the second position is attained, let go the second anchor, order astern movement of the engines, and pay out on the second anchor cable. The first anchor cable will act as a check until both cables have an even scope, once this situation is achieved then cables can be payed out together as required to obtain the final position of mooring.

Masters should bear in mind that with this method, the first anchor may be turned out of the holding ground when the vessel gathers sternway after the second anchor has been released. To this end it may become prudent to check both cables prior to coming to rest, so ensuring that both the second and the first anchors are bedded in and holding.

Baltic Moor

The vessel should approach the berth with the wind on the beam or slightly abaft the beam. The stern mooring wire should be secured in bights by light seizings in the forward direction to join the ganger length of the anchor cable before the approach is begun. Then proceed as follows:

1. Manoeuvre the vessel to a distance off the berth of two or three shackles of cable. This distance will vary with the wind force and expected weather conditions.

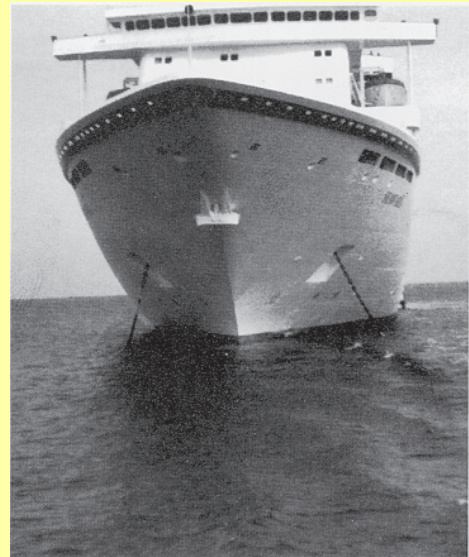

30. Cruise ship moored, deploying both Port and Starboard anchors. N.B. Additional centre anchor in stowed position.

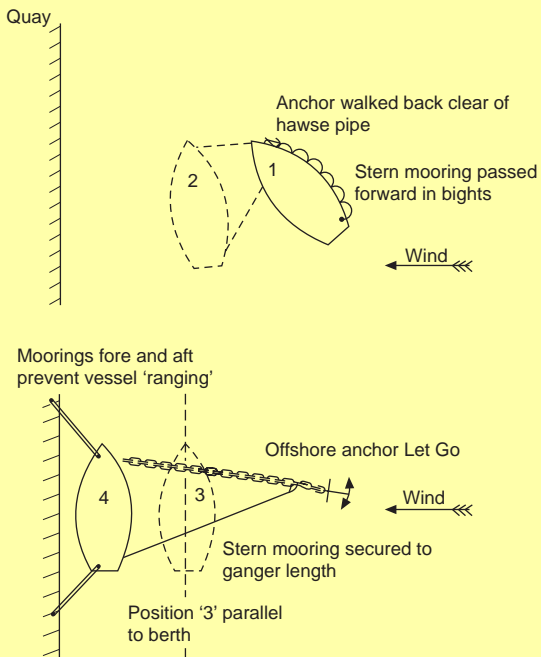

Figure 9.42 Baltic moor.

2. Let go the offshore (starboard) anchor. The weight of the anchor and cable will cause the sail twine securing on the mooring wire to part, and as the cable pays out, so will the stern mooring wire.
3. Let the wind push the vessel alongside, while you pay out the cable and the stern wire evenly together.
4. Use ship's fenders along the inshore side between the vessel and the quay, then pass head and stern lines as soon as practical.
5. Secure head and stern lines on the bitts before taking the weight on the anchor cable and the stern mooring wire. This tends to harden up the inshore (port) moorings.

One reason behind the Baltic moor is that many ports experience strong Onshore winds.

When the vessel comes to let go and depart the port, unless she is fitted with bow thrust units, the Master may encounter difficulties in clearing the berth. However, heaving on the anchor cable and on the stern mooring will allow the vessel to be bodily drawn off the quay. Once clear of the berth, full use can be made of engines and helm to get under way.

The main disadvantage of this moor is that time is required to let the stern mooring go from anchor/cable. To this end the size of shackle used and the possibility of allowing it to pass up the hawse pipe are critical factors. Alternatives are to find a lee for the vessel for the purpose of disengaging the stern mooring.

Mediterranean Moor

This moor is carried out usually for one of two reasons – either quay space is restricted and several vessels are required to secure or a stern loading/discharge is required. (As for a tanker.) The object of the manoeuvre is to position the vessel stern to the quay with both anchors out in the form of an open moor. The stern of the vessel is secured by hawsers from the ship's quarters to the quay.

This type of mooring (Figure 9.43) is not unusual for tankers using a stern load or discharge system. However, a disadvantage to the dry cargo vessel lies in the fact that cargo must be discharged into barges. It is not a favourable position in bad weather and there is a distinct possibility of fouling anchor cables, especially when other vessels are moored in a similar manner close by. The procedure is as follows:

1. Approach the berth, as near parallel as possible to the quay. Let go the offshore anchor. Main engines should be ahead and dead slow.
2. Rudder should be positioned hard over to turn the vessel away from the quay. Continue to let the cable run, and pay out as the vessel moves ahead. A check on the cable as the vessel starts to turn would accentuate the turn, and produce astern-to orientation for the vessel. Stop main engines.
3. Let go the second anchor, and come astern on main engines, paying out the cable on the second anchor. As the vessel gathers sternway,

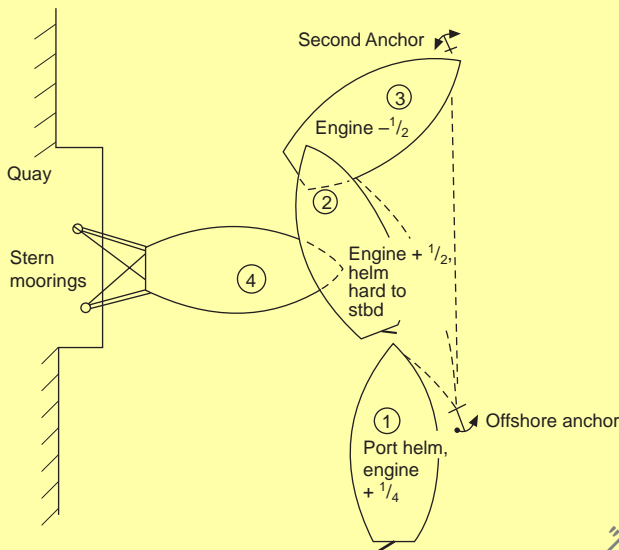

Figure 9.43 Mediterranean moor.

recover any slack cable on the offshore anchor. Stop engines and check the sternway on the vessel, as required, by braking on the cables.

- Manoeuvre the vessel to within heaving line distance of the quay by use of engines and cable operations. Pass stern moorings to the quay. Tension on the moorings is achieved by putting weight on to the cables once the moorings have been secured on bitts.

Dredging Down

A vessel is said to be 'dredging down' when she is head to the wind and/or tide (stemming the tide), with an anchor just on the bottom. The amount of cable out is limited to the minimum to put the anchor on the bottom. Dredging down occurs when the vessel is not moving as fast as the current, which makes the rudder effective and allows the ship to manoeuvre. It is normal to expect a crabwise motion of the vessel over the ground, which is often employed for berthing operations. Used in conjunction with bold helm, the direction of the ship's head can be appreciably changed.

Snubbing Round

A vessel can turn head to tide without too much difficulty, provided that there is sufficient sea room to do so. Should the sea room not be available then a tighter turn will be required. This can be achieved by means of one of the ship's anchors, in the operation of snubbing round on the weight of the cable.

It is most frequently practised when the vessel has the tidal stream astern or in berthing operations. The vessel's speed should be reduced so that she can just maintain steerage way. Let go either the port or starboard anchors, at short stay, and allow the cable to lead aft, dragging the

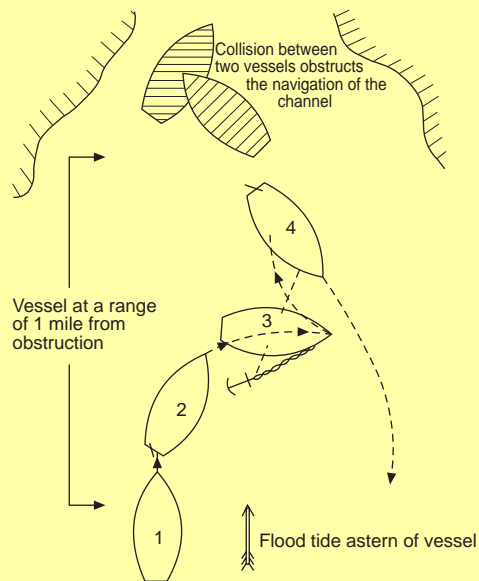

Figure 9.44 Emergency anchor to avoid obstruction.

anchor along the bottom. The cable will act as a spring, reducing headway, and canting the bow round towards the side from which the anchor was let go. The Master or pilot of the vessel should supplement this anchor/cable action by use of maximum helm and increase in engine power to bring the vessel through 180°. The anchor party should be briefed on the operation beforehand, and know, when to apply the brake to the cable, so giving the check on the vessel's forward motion that is necessary to complete the turn.

If the manoeuvre is attempted with too much headway on the vessel, excessive weight will be brought on to the cable as the vessel turns, which could result in the cable parting. In general practice, the anchor is let go to about a shackle, depending on the depth of water. The brake is then applied to start the turning motion on the vessel.

Anchoring in an Emergency

A vessel is approaching a channel in reduced visibility, speed 5 knots. The officer of the watch receives a VHF communication that the channel has become blocked by a collision at the main entrance (Figure 9.44). What would be a recommended course of action when the vessel was 1 mile from the obstructed channel, with a flood tide of approximately 4 knots running astern?

1. Assuming the vessel to have a right-hand fixed propeller, put the rudder hard a-starboard and stop main engines. The vessel would respond by turning to starboard. The anchor party should stand by forward to let go starboard anchor.
2. Let go starboard anchor. Full astern on main engines to reduce headreach. Letting go the anchor would check the headway of the vessel and act to snub the vessel round. Stop main engines.
3. Full ahead on main engines, with rudder hard a-starboard. Ease and check the cable as weight comes on the anchor. Once the vessel has stopped over the ground, go half ahead on main engines, allowing the vessel to come up towards the anchor and so relieve the strain on the cable. Heave away on the cable and bring the anchor home. Clear the area and investigate a safe anchorage or alternative port until channel obstruction is cleared.

INTERACTION

Most vessels will at one time or another experience some form of interaction with another vessel, perhaps through navigating in shallow water or passing too close to an obstruction. In this age of the big ship Masters and pilots should know exactly what interaction is and what the results of its occurrence may be.

Interaction is the reaction of the ship's hull to pressure exerted on its underwater volume. This pressure may take several forms (Figures 9.45 to 9.48).

Interaction in Narrow Channels

Vessels navigating in narrow channels (Figures 9.49 to 9.51) may also see telltale signs of interaction, e.g. when passing another vessel which is moored fore and aft. The interaction between the vessels will often cause the moored vessel to 'range on her moorings'. A prudent watchkeeper on that vessel would ensure that all moorings were tended regularly and kept taut. The experienced ship-handler would reduce speed when passing the moored vessel to eliminate the possibility of parting her mooring lines.

Another telltale sign, again in a narrow channel such as a canal, may be noticed when a vessel is navigating close to the bank. As the vessel proceeds, a volume of water equal to the ship's displacement is pushed ahead and to the sides of the vessel. The water reaches the bank and rides up it. Once the vessel has passed, the water falls back into the cavity in the ship's wake. The interaction in this case is between the hull of the ship and sides of the bank. An increase in squat may be experienced because of the loss of water under the vessel's keel. This may even bring about the vessel grounding. The effects may be reduced by a reduction in speed, provided steering is not impaired by such action.

Attention is drawn to MGN 18 regarding *Interaction between Ships*.

SHALLOW WATER EFFECTS AND SQUAT

When a vessel enters shallow water, she experiences a restricted flow of water under the keel, which causes an apparent increase in the velocity of water around the vessel relative to the ship's speed. Consequently, an increase in the frictional resistance from the ship's hull will result.

If the increase in the velocity of water is considered in relation to the pressure under the hull form, a reduction of pressure will be experienced, causing the ship to settle deeper in the water. The increase in the frictional resistance of the vessel, together with the reduction of pressure, may result in the ship 'smelling the bottom'. A cushion effect may be experienced, causing an initial attraction towards shallow water, followed by a more distinct 'sheer' away to deeper water.

Where shallow water is encountered in confined waters, e.g. channels and canals, a 'blockage factor' (Figure 9.50) must be taken into account. Ships may sink lower in the water when the blockage factor lies between 0.1 and 0.3; this, combined with a change of trim from the shallow water effect, is generally expressed as 'squat'. The result of a vessel squatting will be a loss of clearance under the keel, making steering and handling difficult.

Vessels navigating with a blockage factor between 0.1 and 0.3 push a volume of water ahead. This water, carried back along the sides of the channel to fill the void left astern of the ship, is often referred to as the 'return current'. The rate of the returning water has an effect on the ship's speed, and the maximum speed that the vessel can reach becomes a limited factor known as 'canal speed'.

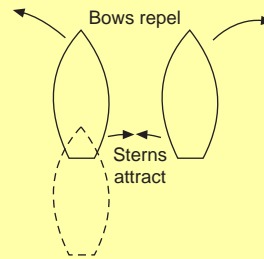

Figure 9.45 Overtaking, when two vessels are passing too close to each other on parallel courses. Interaction may occur when the vessels are abeam, resulting in deflection of the bows and attraction of stern quarters, with dangerous consequences.

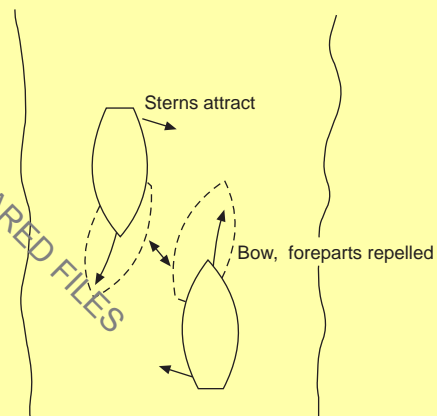

Figure 9.46 Interaction between two vessels on reciprocal courses.

The period of time in which interaction is allowed to affect both vessels is limited because the pressures and water cushions created only last during the period of passing. When vessels are on reciprocal courses, the length of time that the vessels are actually abeam of each other is short (as opposed to one vessel overtaking another).

No problems arise when both vessels have ample sea room. However, in narrow channels there is the danger of grounding or collision as bows are repelled and sterns pulled towards each other.

Figure 9.47 Situations involving interaction.

Above, interaction occurring between a vessel and a bank, sometimes referred to as a bank cushioning effect. A vessel with helm amidships may create an area of increased pressure between her hull and the bank. The result is that the vessel appears to be repelled from the bank while her stern is apparently sucked into the bank, with obvious dangers to rudder and propellers.

Below, interaction occurring between the vessel's hull and the sea bed when in shallow water (shallow water effect). When approaching a shallow water area, a vessel may initially be attracted to the shelving or the obstruction. However, as pressure builds up between the hull and the sea bottom, the vessel may experience a sudden and decisive shear to one side or the other. Rudder effect may also be reduced by turbulence caused by a reaction from the sea bottom.

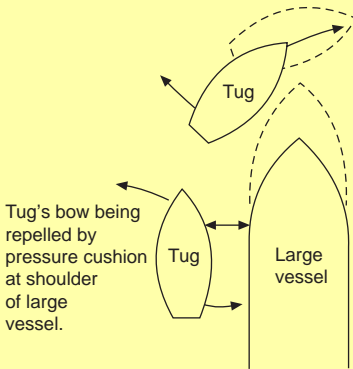
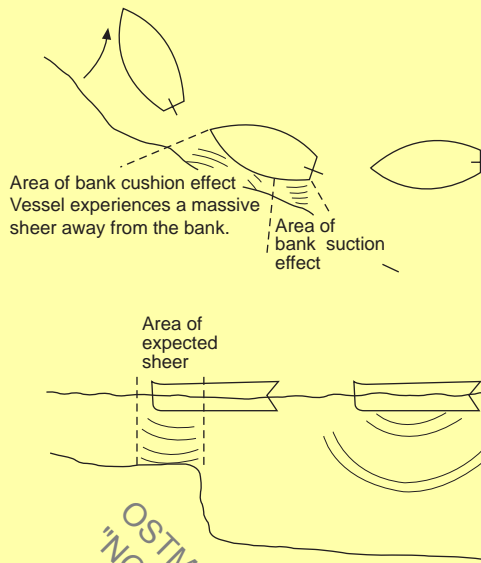

Figure 9.48 Interaction between large vessel and tug.

1. As the tug approaches the larger vessel to collect the towline, its bow is repelled by the shoulder of the larger vessel.
2. Counter helm is applied to correct the outward motion of the tug.
3. As the tug moves ahead under the bow of the larger vessel, it experiences an attraction to the larger vessel accentuated by the tug carrying the counter helm.
4. Unless prompt action is taken by the helmsman on the tug, the two vessels could collide, with the tug passing in front and under the larger vessel's bow.

Influencing Factors on Squat

1. The speed of the vessel.
2. The rpm in relation to the 'canal speed'.
3. The type of bow construction, which will affect the bow wave and distribution of pressure.
4. The position of the longitudinal centre of buoyancy (LCB), near or through which the downward force of squat will probably act.

Squat may occur by the head or by the stern. If the LCB is aft of the centre of flotation, a squat by the stern would be expected; and if the LCB is forward of the centre of flotation, the vessel would be expected to settle by the head.

The strongest influence on the amount of squat will be the speed of the vessel. As a general guide, squat is proportional to the square of the speed. A reduction in speed will lead to a corresponding reduction in squat.

WORKING WITH TUGS

The function of the tug is to assist the pilotage of a vessel. This function has brought many types of tug into being, the most common being the ocean-going tug and the smaller dock tug (Figure 9.52 and Plate 31). Extensive use of supply vessels in the dual-purpose role of supply and towing have caused design and construction firms to add towing facilities to many supply vessels. Use of tugs while entering a lock is shown in Figure 9.53.

The very nature of the employment of tugs underlines the fact that tremendous weight and stresses have come into play, with consequent risk to operators. Many accidents have occurred in the past on mooring operations, and a considerable number of these have been during the use of tugs and their towlines.

Safe Handling of Towlines

1. Seamen should never stand in the close vicinity of a towline when stress is seen to be in the line.
2. Towlines should always be let go in a controlled manner (by use of rope tail from wire eye) to ensure that the tug's crew are not endangered.
3. Sharp angled leads should be avoided.
4. Chafe on towlines should be avoided, especially over long periods, by parcelling the towline and lubricating any leads employed. Means of adjusting the length of the towline to avoid continual wear and tear or in the event of bad weather should be provided.
5. It is not considered good seamanlike practice to secure the eye of a tug's wire over the vessel's bits. The control of the station is then passed to the tug, and the ship becomes dependent on the tug's Master to come astern. Effectively this eases the weight on the towline and allows the ship's personnel to slip the tow. However, in an emergency, if the eye had been secured over the bits, the ship's personnel would not have been able to release the towline.
6. When a ship's towrope is released from a stern tug, in the majority of operations main engines should be turning ahead. The screw race will tend to push the towline well astern and clear of the propeller. This also occurs with a towing wire when fitted with a nylon pennant. The majority of man-made fibre ropes float as they are stretched astern, providing the officer on station with more handling time to bring the towline aboard, without fouling the propeller.
7. After any towline has been secured by turns aboard the vessel, the weight should be taken to test the securing before the start of actual towing operations.
8. Efficient communications should be established between the bridge, the tug, and the officer on station, before starting the tow.

Girting or Girding

This is a term used to describe a tug being towed sideways by the vessel she is supposed to be towing. The danger arises when the towing hook is close to midships. The height of the towing hook is an important factor, as are the speed and rate of swing of the towed vessel.

This situation could be extremely dangerous if the tug's gunwales are dragged under by the force of the vessel under tow acting on the towline, especially if the weather deck of the tug has open hatchways. If in an emergency the tug's stern cannot be brought under the towline very quickly, the tow should be slipped (see Figure 9.54).

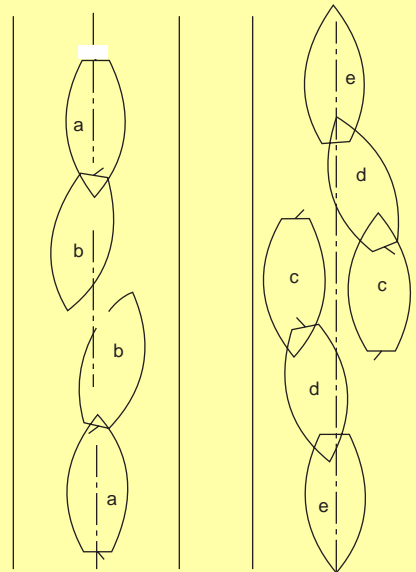

Figure 9.49 Recommended passing positions for two vessels in opposition in narrow channel.

The limits for vessels passing when navigating in narrow channels can often be extremely fine. Both vessels are recommended to reduce speed in ample time in order to minimise the interaction between ship and ship and ship and bank. Provided a sensible speed is adopted, it should prove unnecessary to alter the engine speed while passing, thus keeping disturbance and changing pressures to the minimum as the vessels draw abeam.

In normal circumstances each vessel would keep to her own starboard side of the channel (ab and cde), and good communications should be established before the approach to ascertain exactly when the manoeuvre will start. Efficient port/harbour control can very often ease situations like this simply by applying forward planning to shipping movements.

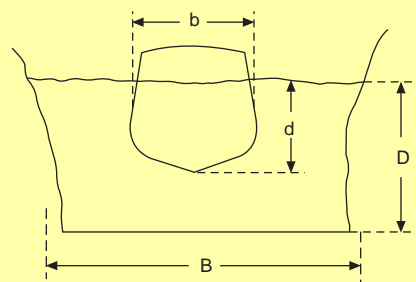

Figure 9.50 Blockage factor.

$$\text{Blockage factor} = \frac{b}{B} \times \frac{d}{D}$$

Example

Let $b = 45'$; $B = 100'$; $d = 26'$; $D = 78'$

$$\therefore \text{Blockage factor} = \frac{45}{100} \times \frac{26}{78} = \underline{\underline{0.15}}$$

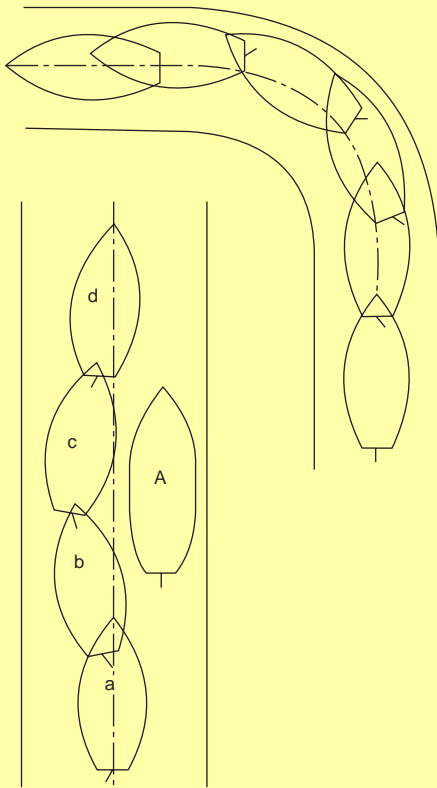

Figure 9.51 Recommended positions when rounding a bend (above) or overtaking another vessel (below) in narrow channels.

Long-distance Towing

Should a vessel have to be towed, owing to engine failure or some other reason, then she will require secure towing arrangements aboard. Experience has shown that if an efficient method of securing is established at the beginning of the towing operation, considerable time and effort will be saved at a later date in the event of the towline parting.

One suggested method of forward securing is by means of a chain cable bridle, constructed from one of the towed vessel's anchor cables. (Figure 9.55). An anchor will need to be hung off, either in the hawse pipe or from the shoulder, leaving the second anchor housed in position and clear ready for use, should it be required.

Preventer wires or relieving tackles, with the weight taken up, should be secured to the bight of the bridle before the towline is secured to it by a heavy duty shackle. Ample grease or other lubricant should be applied to the fairleads and bollards which are expected to take the full weight of the bridle once it is connected to the towing vessel.

The bearing surface of the chain bridle could be adjusted if relieving tackles are used instead of preventer wires, and that would prevent continuous chafe at any one point on the bridle. Lubrication and stress on the bridle should regularly be checked, but personnel should in general avoid the vicinity of the towline and bridle when weight is being taken up by the towing vessel.

The preparation of the chain cable bridle is a lengthy one and mariners should take account of the manpower required and the time to complete the operation before expecting to get under way. Securing the bridle is a lengthy process even in ideal weather conditions, but should the towline part, say in heavy weather, the mariner may find the task of re-securing the tow even more difficult.

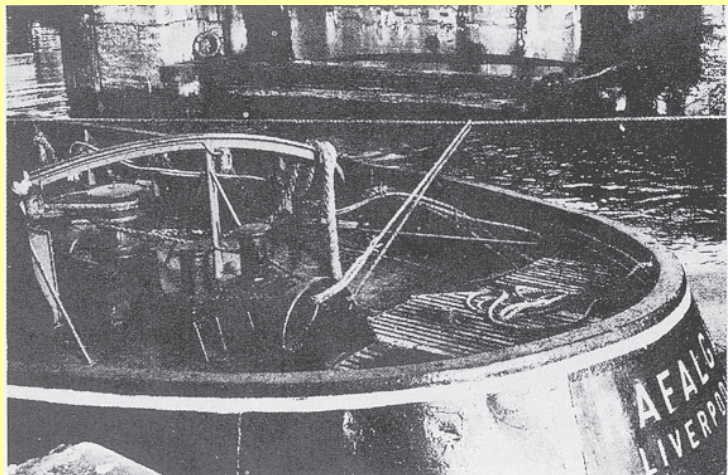

31. Gob rope in use with a ship's towline on the afterdeck of a docking tug. Tension is achieved in the gob rope by means of a centre line capstan. The 'towing rail' is clearly seen running a thwartships.



32. Alternative type of gob rope (wire) and electric winch.

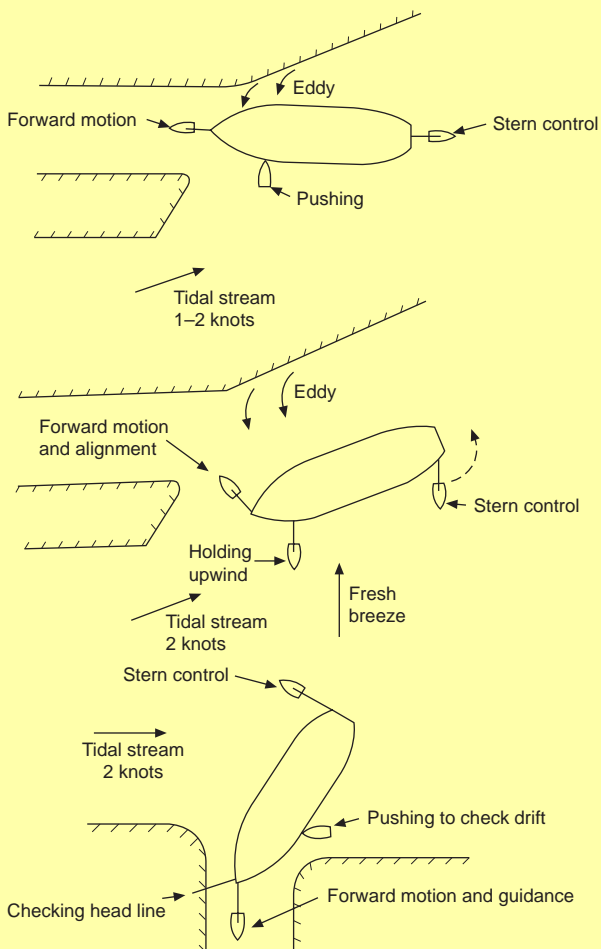
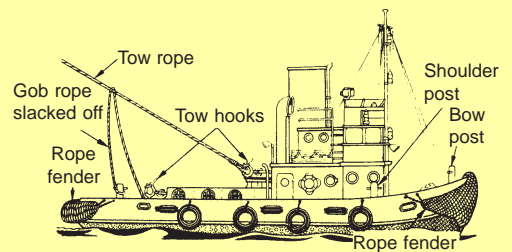
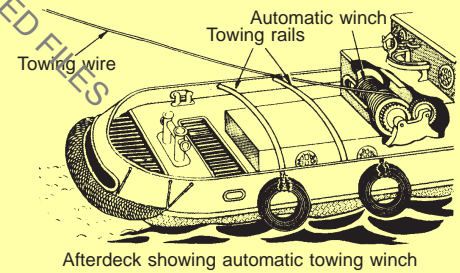

Figure 9.53 Entering a lock – use and deployment of tugs.



Afterdeck showing automatic towing winch

Figure 9.52 Dock tug.

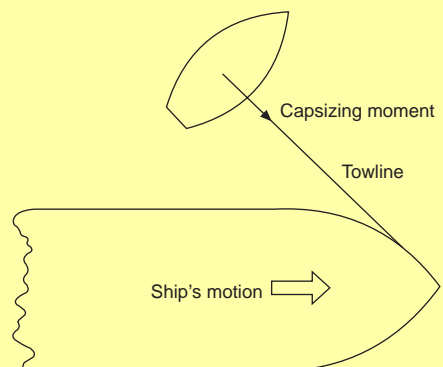

Figure 9.54 Girting or girding.

Alternative Towing Methods

See Figure 9.56.

1. The towing vessel's insurance wire can be combined with the anchor cable of the vessel under tow. The wire from the towing vessel can be secured around the mast, about the aft mast housing, the deck house or the poop itself. Sharp leads will need to be well parcelled and protected by wood to prevent chafe and the tow parting. The main disadvantage of using the anchor cable of the towed vessel is that the anchor is usually hung off at the shoulder, and the vessel under tow cannot use this anchor in an emergency. This fact may not seem important at the onset of the tow, but the anchor could play an important role in reducing the ship's momentum once the destination has been reached. The obvious advantage of employing the anchor cable is that the length of towline can be adjusted by direct use of the windlass. The anchor may remain in the hawse pipe, with the cable passing through the centre lead (bullring if fitted).
2. An alternative method of towing is possible when the tug is fitted with an automatic winch. The handling of the towline is made relatively easy once the cable or chain bridle of the vessel under tow has been secured. The lengthening and shortening of the towline is carried out by manual operation of the winch, while the tension in the towline is controlled automatically under normal towing conditions. This method should not be attempted by vessels using a conventional docking winch, as the additional strain brought to bear on the axis of the winch could render it inoperative.
3. A wire towing bridle can be used. In this method the towing bridle is secured to the vessel doing the towing operation, not the vessel being towed. This bridle is rigidly secured in position by preventer tackles and set around the after housing (poop area). Sharp corners should be well parcelled to prevent chafe and lubricants applied to bearing surfaces of the towline whenever necessary.

A combination of 'rope spring' and steel wire hawser is employed, with the wire hawser being secured around four sets of bits. The main advantage of this method is that both anchors are left ready for use, but adjusting the length of the towline can prove a lengthy and sometimes dangerous task.

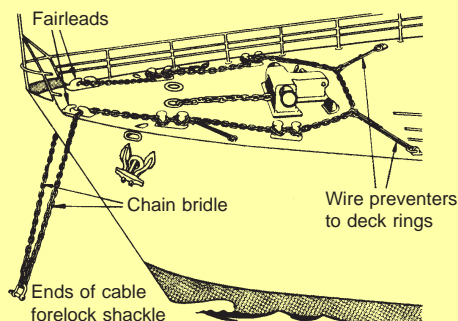
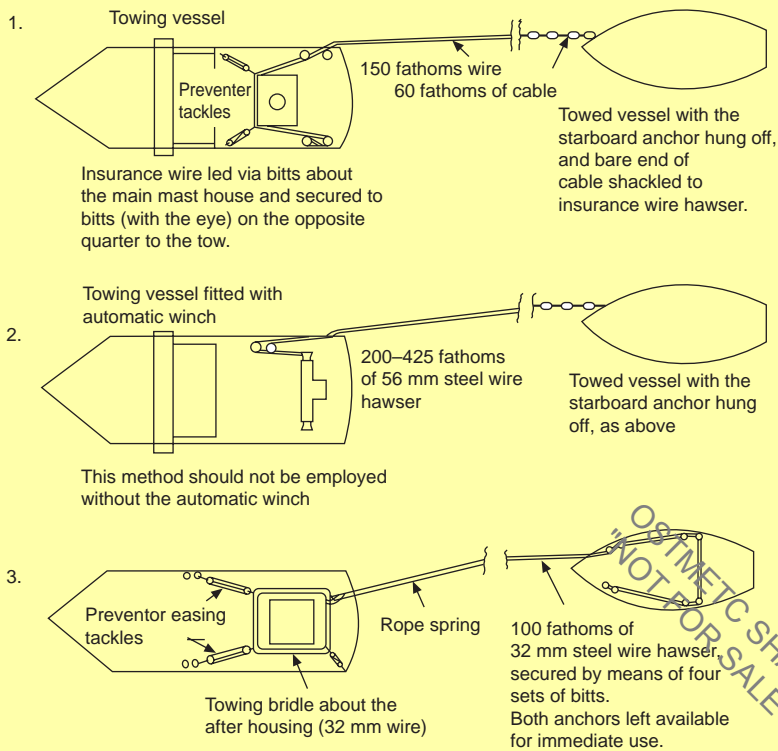

Figure 9.55 Method of securing chain bridle.



Examples 1 and 2 show use of composite towlines employing tugs towing spring and the towed vessels anchor cable.

Figure 9.56 Towing methods.

Use of Two Tugs

This method (Figure 9.57) has the obvious advantage of giving more power on the towlines and increasing the speed of the tow. However, the expense of employing two tugs instead of one is considerable, especially if one tug can manage the job, though taking a little longer. Certain heavy ULCC and VLCC vessels would, of course, need two or more tugs.

The use of two tugs, one off each bow, has the effect of reducing the yaw of the vessel under tow. Towlines secured on each side will vary in length and construction but should be such as to lead approximately 30° away from the fore and aft line of the parent vessel. This method is often used for towing floating drydocks and the like, as it achieves greater manoeuvrability.

Emergency Towing Arrangements for Large Tankers

In November 1983, the IMO adopted resolution A535(13) regarding emergency towing arrangements applicable to new tankers of 20,000 or over.

The purpose of the resolution, which was published in 1984, and amended, was primarily to reduce the risks of pollution. Recommendations regarding specialised fitments to applicable vessels are as follows:

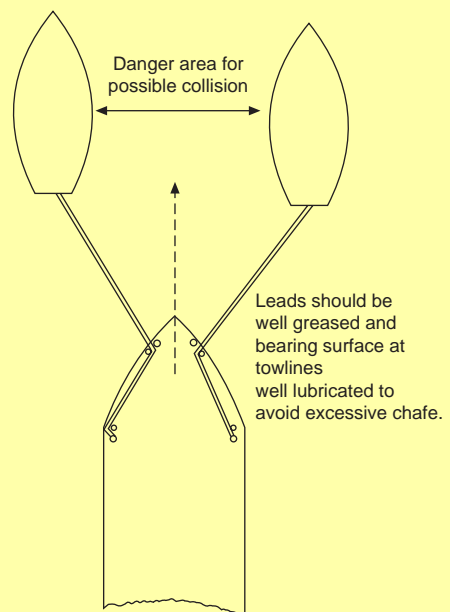
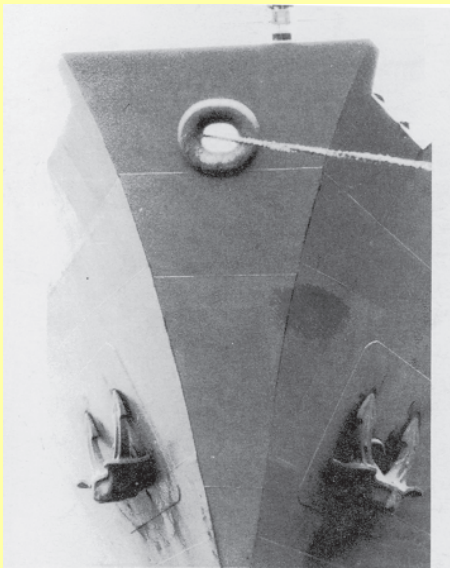

Figure 9.57 Towing by two tugs.



33. Bow section showing centre Panama Lead (Bullring) which can be employed for towing and could eliminate the need to hang an anchor off at the shoulder.

Major Towing Components

For the tug or towing vessel. The towline, a pennant, a chafing chain, a fairlead, and a towing gear connection or strongpoint.

For the vessel being towed: a system which facilitates ease of connection, which is capable of connecting and releasing aboard the towed vessel in the absence of main power.

A standardised point of connection between the towline and the chafe chain should be used.

The Applied Requirements

Emergency towing positions should be fitted at the bow and stern positions of respective vessels. Where a tanker of 100,000 tonnes or over, was built before the adoption of resolution A535(13) then these vessels should have the towing positions fitted at the first scheduled dry docking following adoption but not later than five years after adoption, each position being fitted with a strongpoint, fairlead and chafing chain.

All components of the towing system, including the supporting structure should have a working strength of at least 2000 kN.

The strength being sufficient for all angles of the towing up to 90° from the ship's fore and aft line.

Location and Geometry

The position of the strongpoint and fairlead should be such as to allow towing from either side of the bow or stern. The axis of the towing gear should be, as far as practical, parallel to and not more than 1.5 m either side of the centre line. The fairlead should be positioned in relationship with the strongpoint so that distance between them is not less than 2.7 m and not more than 5 m so sited that the chafing chain lies approximately parallel to the deck when under strain.

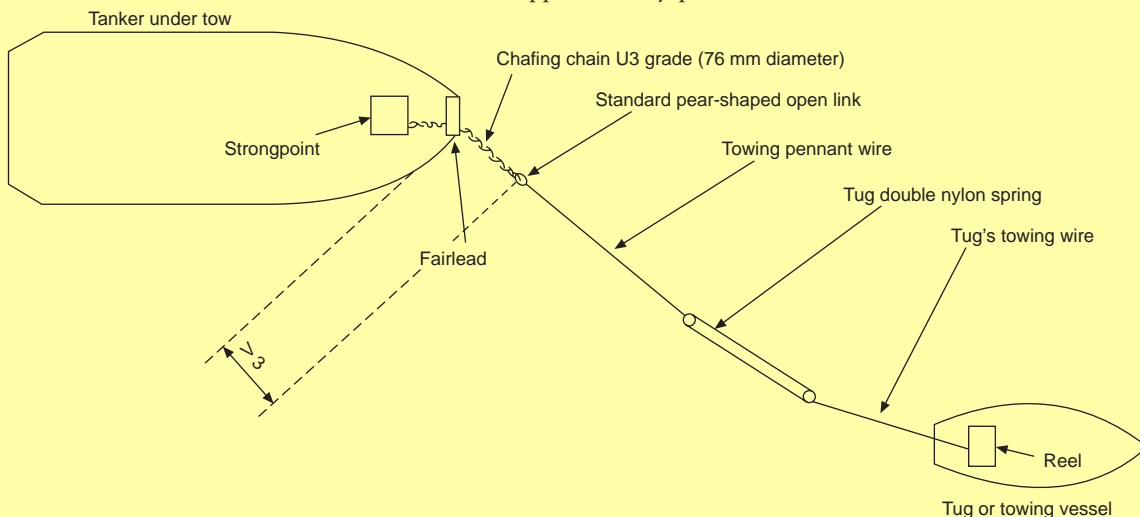

Figure 9.58 Example of emergency towing arrangements for large tankers. Additional reference Volume III, Command Companion of Seamanship Techniques DJ House (2000).

TANKER WORK AND OIL POLLUTION



A large percentage of merchant fleets, not just the British merchant navy, have considerable tonnage in the way of tanker type vessels, the majority of which are carriers of crude oil and the associated oil products. Oil cargoes are usually carried in very large crude carriers (VLCCs) up to 350,000 DWT. Other refined products from the oil industry, e.g. diesel oils, kerosene and gas oils, are normally carried in the smaller product carrier vessels. It is accepted practice that the majority of vessels carry the same type of cargo year after year. This avoids contamination of different categories of oil, and the need to carry a variety of gear for different cargoes, and more than one pumping arrangement.

The obvious hazards in the carriage of these cargoes are fire with or without explosion, the emission of toxic vapours, and oil pollution. Tanker personnel need to understand the following points about the dangers of their calling:

1. *Flashpoint* (of an oil). This is the lowest temperature at which the oil will give off vapour in quantities that when mixed with air in certain proportions are sufficient to create an explosive gas.
2. *Ignition point* (of an oil). This is the temperature to which an oil must be raised before its surface layers will ignite and continue to burn.
3. *Volatile liquid*. This liquid has the tendency to evaporate quickly, and has a flashpoint of less than 60°C.

TANKER VESSELS

General Petroleum Tankers

Crude oil carriers, mainly the larger type of tanker, these comprise:

1. Supertankers of 50,000 to 160,000 tonnes.
2. Very large crude carriers (VLCCs) of 160,000 to 300,000 tonnes.
3. Ultra large crude carriers (ULCCs) of 300,000 tonnes and over.

Refined Product Carriers

Mainly smaller tankers up to 50,000 tonnes, these are divided into carriers of *clean oils* such as motor spirit, naphtha, kerosene and gas oil; and carriers of *black oils* such as fuel oil, diesel oils and furnace oils, carriers of one category never move into the other.

Specialised Carriers

Vessels falling into this category generally require specialist construction and operating procedures. Examples include gas carriers, chemical carriers, liquid (molten) sulphur carriers, bulk wine carriers and bitumen carriers.

TANKER HAZARDS AND PRECAUTIONS

Fire and Explosion

1. *The most dangerous condition of an oil tank* is when the cargo has been discharged, and before any tank cleaning and gas freeing has been carried out. When a cargo tank is full, the possibility of fire is present but explosion risk is quite small since the air/hydrocarbon vapour atmosphere above the oil is small. When the tank is empty, however, the air/hydrocarbon vapour atmosphere is at its maximum. If the atmosphere is within the flammable limits for air/hydrocarbon mixtures, the tank is extremely susceptible to explosion.
2. *Oxygen analyser and explosimeter.* Oxygen analysers come in several forms. Some are electrically operated and can give continuous readings of oxygen content of the atmosphere being sampled. Others measure oxygen content of the sample by chemical reaction and will only last for a limited number of tests before renewal of the chemical is required. These oxygen analysers are used to check whether there is sufficient oxygen in an enclosed space to support life, as well as in other tanker operations where oxygen content is required.

An explosimeter is designed to measure the flammability of a gas sample. The instrument is calibrated to read from 0 to 100 per cent of the lower flammable limit of the gas sample. For most air/hydrocarbon atmospheres in normal tankers the lower flammable limit (LFL) is about 1 per cent hydrocarbon gas by volume whilst its upper flammable limit (UFL) is about 10 per cent hydrocarbon gas by volume.

3. *Fixed fire-fighting systems.* These systems are permanently installed systems with a specific coverage and function. These systems take many forms of which the following are some of the more commonly used.

Fixed foam systems utilise a centralised foam tank to supply a fixed system covering a specific area that may be susceptible to oil fires. Typical areas covered by fixed foam systems are engine-room and boiler-room bilge areas and pump-room bilge areas. A tanker's main cargo deck is often covered by fixed foam monitors supplied from a centralised foam tank. The most commonly used foam is of a

protein-based type which uses water as its drive and combining agent. Specialised foams such as Hi-Ex (high expansion) foam may be found but are not, as yet, the most common type.

Foam is the best agent for extinguishing oil fires, as it floats across the surface of burning oil and thus reaches wherever the oil itself reaches. Once the surface of the oil is covered, the fire is effectively smothered. The foam blanket must be maintained until the oil temperature has fallen sufficiently to reduce the risk of re-ignition.

Fixed CO₂ (carbon dioxide) systems utilise a centralised CO₂ room containing the required number of CO₂ gas cylinders to provide coverage for the area being protected. The CO₂ bottles are pressurised and thus provide their own drive when released. The CO₂ is used to displace air from a fire, thus smothering it. CO₂ is a non-conductive agent and can thus be used in the area of electrical switchboards and is also used for pump-room smothering, though electrostatic charging has to be guarded against.

Fixed BCF (bromochlorodifluoromethane) is a vapourising liquid which is an excellent smothering agent but is costly and like CO₂, is only usable once and is not fitted to many vessels on the large scale employed with most fixed systems. It is sometimes found as a fixed system in emergency generator rooms of the diesel-operated type.

Fixed dry powder systems are frequently found in emergency diesel generator rooms. The dry powder smothers the surface of the fire; it is non-conductive and may be used on electrical equipment, though it may cause damage due to its abrasive properties.

Steam smothering systems may be used, particularly in older vessels, for smothering cargo and pump-room spaces. Steam smothering does not help to reduce temperature and may sometimes cause gas generation from oil which it may heat.

Water wall systems are often fitted at the front of tanker deck-houses to stop radiant heat affecting the accommodation owing to a cargo tank fire. Water is pumped through spray nozzles, high on the accommodation front, and falls as a water curtain.

Inert gas is not specifically a fire-fighting system but may be utilised in cargo tanks. It is often possible to fit a portable bend to allow inert gas into a pump-room space.

4. *Portable fire-fighting equipment.* Small portable fire-fighting equipment is designed to act as first aid in the event of a fire. If a fire is tackled at an early stage, it may be put out by small portable equipment. If a fire is larger than can be handled by small portable equipment, then larger equipment requiring greater manpower must be used or one of the fixed systems may be resorted to, if available. Small portable equipment is supplied in many types similar to the fixed systems except in their size.
5. *Common sources of ignition:*
 - Smoking* – particularly dangerous are striking matches or lighters.
 - Galleys* – oil or electric, i.e. burners, toasters etc.

Accommodation electrical equipment – not usually designed to be gas-tight so flammable gas must be kept out.

Metals – ferrous and non-ferrous metal tools should be used with care. Non-ferrous metal tools are only marginally less likely to cause incendive sparks and have other drawbacks such as the danger of ‘thermite’ spark or flash which may be incendive in the presence of flammable gas.

Spontaneous combustion can occur with most combustible organic materials, some being more susceptible than others. Auto-ignition was previously discussed, and is a serious hazard where oil may come into contact with hot surfaces (see pp. 173, 177 and 186).

Ship/shore electrolytic may occur in sufficient intensity to cause incendive sparks at a ship’s manifold and insulating pieces are frequently used to reduce this risk.

Static electricity can be generated by fluid flow.

Lightning during thunderstorms or electrical storms should cause a cessation of operations whilst it is in the vicinity of a tanker.

6. *Intrinsically safe.* A circuit, or a part of a circuit, is intrinsically safe when any spark or thermal effect produced normally, or accidentally, is incapable, under prescribed test conditions, of causing ignition of a prescribed gas or vapour.
7. *Tanker Safety Guides.* The Tanker Safety Guide issued by the International Chamber of Shipping should be available for reference on all tankers. Tanker owners also issue their own rules and regulations and these should be read and adhered to.
8. *Emergency plans and procedures.* Emergency plans and procedures to cover all foreseeable situations should be drawn up and then practised at regular intervals. On first joining a ship, the prudent mariner will familiarise himself with the plans and procedures for the ship and his position in those plans. Careful attention should be paid during practise sessions so that the need to think in an emergency is kept to a minimum, everyone should automatically do the correct thing even under the stress of a possible panic.
9. *Ship/shore checklist* (see p. 253).

DANGERS OF PETROLEUM SPIRIT

Should petroleum ignite, it is the vapour given off by the liquid that burns, not the liquid itself. However, temperatures are such that the liquid vaporises quickly. As with all fires, the vapour will only burn if the air/oxygen supply has access to the fire. The volume mixture of vapour to air defines the upper and lower explosive limits, which normally lie between 1 and 10 per cent.

Once a liquid is burning, volumes of gas will be given off. The consequences of the build-up of this gas, especially in an enclosed space, could be disastrous and lead to explosion. Risk of explosion is more likely with the expansion of the gas within the space.

Petroleum vapour can have a variety of effects on the human body, depending on the quantity. Some types of vapour are toxic, and if inhaled

SHIPHANDLING

TABLE 10.1 Ship/shore (tanker) officer's example checklist

VESSEL BERTH No.	DATE TIME			
1. Are SMOKING regulations being observed?				
2. Are GALLEY requirements being observed?				
3. Are NAKED LIGHT requirements being observed?				
4. Are electric cables to portable equipment disconnected from power?				
5. Are the ship's main transmitting aerials switched off?				
6. Are hand torches of an approved type?				
7. Are portable R/T sets of approved design?				
8. Are all external doors and ports in the amidships accommodation closed?				
9. Are all doors and ports in the after accommodation that are required to be closed in fact closed?				
10. Are ventilators suitably trimmed with regard to prevailing wind conditions?				
11. Are unsafe air conditioning intakes closed?				
12. Are window-type air conditioning units disconnected?				
13. Is ship securely moored and agreement reached on use of tension winches?				
14. Are cargo/tanker hoses in good condition?				
15. Are cargo/bunker hoses properly rigged?				
16. Are unused cargo/bunker connections blanked?				
17. Is stern discharge line (if fitted) blanked?				
18. Are sea and overboard discharge valves (when not in use) closed and lashed?				
19. Are scuppers effectively plugged?				
20. Is the agreed ship/shore communication system working?				
21. Are all cargo/bunker tank lids closed?				
22. Are cargo tanks being loaded or discharged open to atmosphere via the agreed venting system?				
23. Are fire hoses and equipment ready for use?				
24. Are emergency towing wires correctly positioned?				
25. Is the ship ready to move under its own power?				
REMARKS:				

OSTMETC SHARED FILES
"NOT FOR SALE"

We have checked with each other the items on the above checklist and have satisfied ourselves that the entries we have made are correct to the best of our knowledge.

CHECKED BY: _____ (for ship) _____ (for Terminal)

in a large enough quantity could prove fatal. If a lesser quantity is inhaled the person exposed may develop the symptoms of a drunken state. A person's sense of smell may also be affected by petroleum vapour, so reducing the body's warning systems for detecting the presence of gas.

GENERAL DEFINITIONS

Clean Ballast

Clean ballast is water carried in a cargo tank that has previously been thoroughly washed, as have the pipelines serving it.

Dirty Ballast

Dirty ballast is water carried in an unwashed tank or ballast that has been contaminated with oil from another source, e.g. loading through dirty pipelines will contaminate ballast.

Gas Lines

When loading, the air or gas originally inside the tank must be allowed to escape or pressurisation will occur. The gas lines connect at the top of the tank and allow this air or gas to escape.

Inert Gas

This gas, which is low in oxygen content, is obtained from the funnel uptake or an inert-gas generator. It is pumped into tanks while cargo is being discharged to reduce the risk of fire or explosion.

Manifold

That point on either side of the vessel where the ship's pipelines are connected to shore pipelines is the manifold. It is usually about the midships point. The valves on the ship's pipelines near the intersection with the manifold are known as the manifold valves.

Permanent Ballast

Ballast water carried in tanks specifically designed for its carriage, known as permanent ballast. There must be no possibility of the tanks being connected to the oil cargo system. (This ballast is not to be confused with the permanent ballast in dry cargo vessels, e.g. concrete blocks.)

Pipelines

These are the pipes used to move cargo around, both when loading and discharging and for any other transfer operation undertaken.

Sounding

The distance from the bottom of the tank to the surface of the liquid in that tank is the sounding. Ullage plus sounding equals the depth of the tank.

Ullage

This is the distance from the measuring point at the top of the tank to the surface of the liquid in that tank.

CARGO-HANDLING EQUIPMENT

Automatic Tank Ullaging Gauge

An automatic gauge sited at the cargo tank and giving continuous reading of ullage, this may be modified to give a remote reading in a control room. It may be operated by spring-tensioned tape and float, by pressure tube, by ultrasonic transducer, or any other approved device.

Flameproof Gauze

Portable brass gauzes are used to cover open sighting ports to stop any flame or spark from flashing back into the tank. Permanent types are fitted in gas lines to prevent flashbacks.

Linen Tape and Brass Weight or Wood Block

Hand-operated, this tape may be used for ullaging or sounding when fitted with a brass weight, but only for ullaging when fitted with a wood block. This type is prone to slight errors, owing to stretch, particularly when the tape is old.

Sighting Port Spanner

The sighting port on the top of a tank hatch may have various types of closing arrangement which usually require a special type of spanner (see Figure 10.1).

Sounding Rod

This rod is usually about 1 m in length and made of brass. It may comprise several short lengths linked together for use in sounding tubes that have bends in them, or it may be solid for other tanks and straight tubes. The rod is attached to a suitable length of line, and may only be used for soundings. Solid rods are frequently used for final 'dips' of oil cargo tanks to find the amount of residues remaining.

Specific Gravity (SG) Glass and Hydrometer

This is a tall sample glass into which is poured a sample of oil from the tank. The hydrometer is then used to measure the specific gravity of the oil, which is used, in conjunction with the oil's temperature and volume, in obtaining the weight of the cargo.

Steel Tape and Brass Weight

Hand-operated, this combination may be used for ullaging or sounding as required. It must not be used where electrostatic charges are present in tank atmospheres, as lightning-like arcing can be a source of ignition.

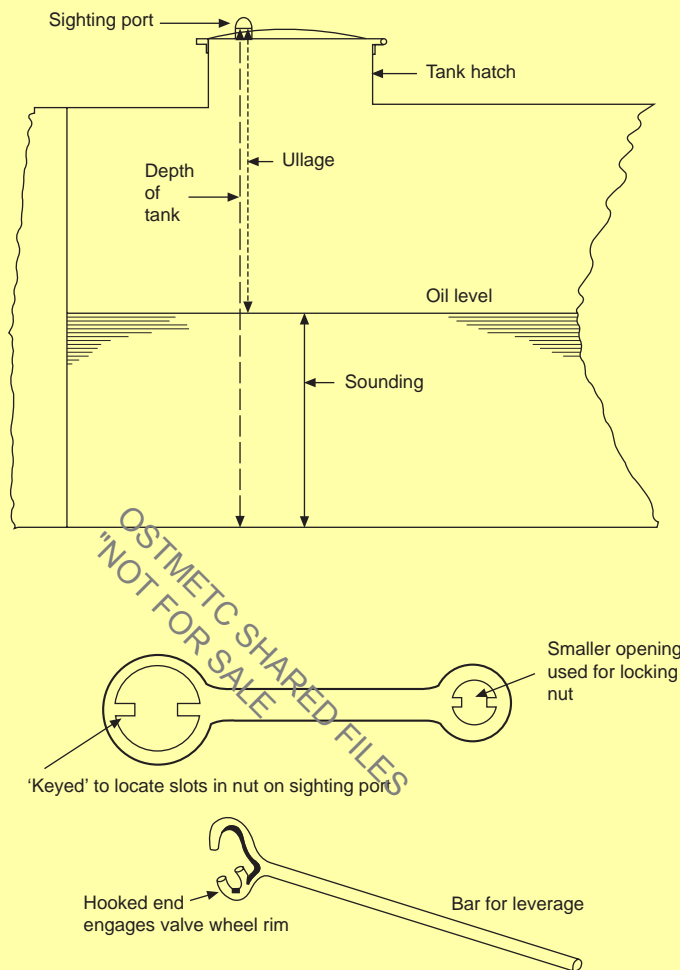

Figure 10.1 Tank measurements (above) and port spanner and wheel key (below).

Temperature Can and Thermometer

The temperature can is made of brass with a narrow neck and weighted base so that it will sink on entering the oil and thus fill with oil. The can is left in the oil for sufficient time to reach the same temperature as the oil, it is then hove up and a thermometer is used to find the temperature. In some cases the thermometer is left in the can when it is in the oil. The can may be adapted for use in obtaining samples of the oil, though a similar but larger sampling can is generally used for this purpose. The temperature of the oil cargo is used in calculating the weight of the cargo.

Ullage Stick

This simple graduated stick about 2 m in length has a cross-piece at the zero graduation mark, and this cross-piece on the ullage opening (usually the sighting port). The stick is used when open loading to finish off a tank, as it only measures the last 2 m of ullage.

Wheel Key

A metal bar with a hook type of end, the wheel key engages with the rim of a valve wheel so that increased leverage is obtained for opening or closing the valve (see Figure 10.1).

Tank measurements are shown in Figure 10.1.

WHESOE TANK GAUGE

The function of the gauge (Figures 10.2 and 10.3) is to register the ullage of the tank at any given time, in particular when the liquid level in the tank is changing during loading or discharging. The gauge is designed to record not only at the tank top but also in a central control room, a transmitter being fitted to the gauge head for this purpose. A particularly useful addition to oil tankers with numerous tanks, it allows the reading of all tanks to be carried out at one central control room.

The unit is totally enclosed and of rugged construction in a non-ferrous metal. Inside the housing is a calibrated ullage tape, perforated to pass over a sprocket wheel and guided on to a spring-loaded tape drum. The tape extends into the tank and is secured to a float of critical weight. As the liquid level rises or falls, the tape is drawn into or extracted from the drum at the gauge head.

The tape-drum is internally spring-loaded and provides a constant tension in the tape, at the float connection, regardless of the amount of tape paid out. A 'counter window' for displaying the tape and fitted at the gauge head allows ullage readouts at any time. (The counter chamber is oil-filled.)

Located inside each tank are a pair of guide wires, each secured to an 'anchor bar' welded to the tank bottom. The upper end of the wires is

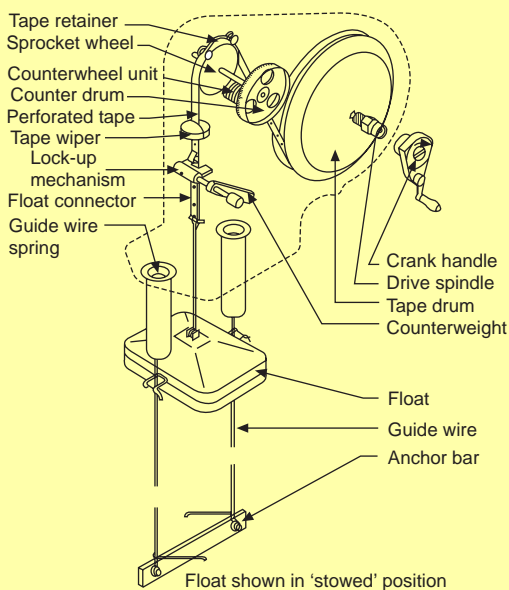

Figure 10.2 Whessoe tank gauge.

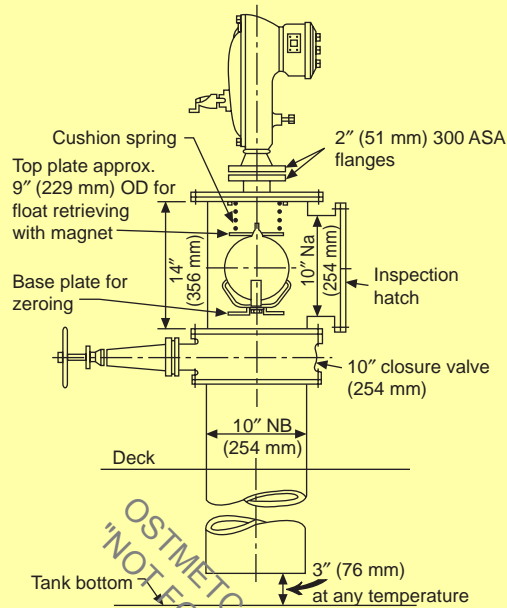

Figure 10.3 Whessoe tank gauge (Model No. 3303) for use with liquefied gas cargoes.

secured to cushion springs beneath the gauge. When the level indicator is not in use, the float is stowed in a locked position under the gauge head. An automatic lock-up arrangement of the float is achieved once the float is raised to its full extremity. Should this fail, the float can be secured manually.

GENERAL OPERATIONS AND PROCEDURES

Procedure when Loading

Clean ballast is discharged overside, dirty ballast is pumped ashore. Tanks should be stripped as dry as possible; they are usually inspected by shore representatives before loading begins. Some tanks may remain empty, and these will usually be about amidships. During discharge of clean ballast, flexible shore hoses are connected to ship's manifold. After tank inspection, ship's lines are set, and loading is started slowly into one tank. When cargo is seen to be coming on board, more tanks are opened and the loading rate increased. A few minutes before completion, 'stand by' is given to the jetty man, and the rate is slowed down. The shore personnel are told to stop operations prior to required cargo levels being reached.

Procedure when Discharging

Ullages etc. are taken and the quantity of cargo on board is calculated. Ship's lines are set for cargo discharge. Simultaneously with these operations, flexible shore hoses are connected to the ship's manifold. When shore indicates that it is ready to receive, the appropriate tank suction valve and the manifold gate valve are opened. Pumping is then started slowly, a

careful watch being kept on the back pressure gauge (indication of valve shut ashore). When it has been established that cargo is being discharged, further pumps may be started and more tanks opened (subject to limitations made by shore).

Ballasting

When a tanker has no cargo to carry on a voyage, or there is insufficient cargo to provide enough sinkage for safety and to ensure the propeller is underwater, then the tanker can take ballast on board from the water in which it is floating.

Tank Cleaning

Where, for any reason, a cargo tank requires cleaning, then modern practice is to use fixed or portable tank-cleaning machines which automatically direct high-pressure jets about the tank in order to wash off oil and oil residues. The washings fall to the bottom of the tank and are then pumped to a special tank called a slop tank where they are retained until it is possible to discharge them to shore facilities (see Figures 10.4 to 10.6).

Safe Entry of Enclosed Spaces

Before one can enter a tank, it must be washed to remove oil so that no further gas can be generated. The tank must then be ventilated, which is usually accomplished by the use of water-driven portable fans or by a large fan in the engine room whose air can be directed to the tank required by the ship's gas lines. Even where a tank has had no oil in it and is clean, the atmosphere must be changed for fresh air, as even rust in a tank will extract vital oxygen from the air in it. Where inert gas has been used, this must be blown out, as it contains far too little oxygen to support life. See Guidelines on p. 268.

Action on Operating Failure

Where *any* operational failure occurs and no one of appropriate authority is present, then the safest course of action is to *stop* operations immediately. Any inconvenience caused by this action is negligible when compared to the possible consequences of continuing in a dangerous state, e.g. fire, explosion, overflow and/or pollution.

Duties of Officer of the Deck During Loading or Discharging

1. Tend moorings.
2. Tend the gangway and supervise the watchman's duties.
3. Calculate the rate of loading.
4. Check fire wires are correctly rigged and ready for use.
5. Check regularly for oil pollution.
6. Ensure that no hot work, naked lights or unsafe lights are left exposed.
7. See ship to shore checklist is observed.

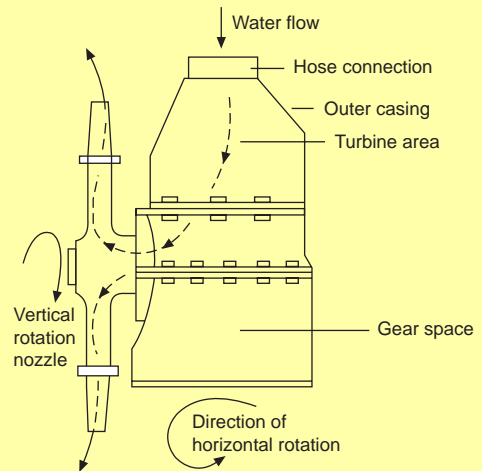

Figure 10.4 Simplified Butterworth 'K' machine. For the cleaning of small and medium tanks. General particulars are as follows:

small and compact, weighing less than 50 lb (23 kg); cleaning range of 10 m; fluid capacity of 31.5 m³ per hour; wash cycle times range from 50–23 minutes for inlet pressure of 3.5–12.3 kg/cm².

Figure 10.5 Butterworth 'Lavomatic SA' machine.

A deck-mounted system for crude oil washing (COW) on large, medium and small tanks, the Butterworth machine has been in use since 1973. It is a fast, economical system of tank washing which meets the standards of MARPOL, IMO, and the UK Department of Trade.

Tank cleaning may begin as soon as the cargo level falls below the wash head. A selection of washing arcs are available from -30° to 150° at 20° increments.

The machine requires 133 wash-head revolutions for a maximum cycle from -30° to 150° and back to -30° . Programme speed can be varied automatically and the system incorporates a manual override for nozzle direction and position.

Washing times can be considerably reduced by prudent adjustment of the revolving wash head. Typical settings would be, say, 1 rpm in the harder to clean lower regions of the tank, and $2\frac{1}{2}$ rpm in the upper easier to clean regions. The discharge rate of the machine would depend on the nozzle size, but the following examples are issued by the manufacturer:

Inlet pressure 10 kg/cm^2 (150 psi).

38 mm nozzle discharges about 150 cu.m per hour.

29 mm nozzle discharges about 100 cu.m per hour.

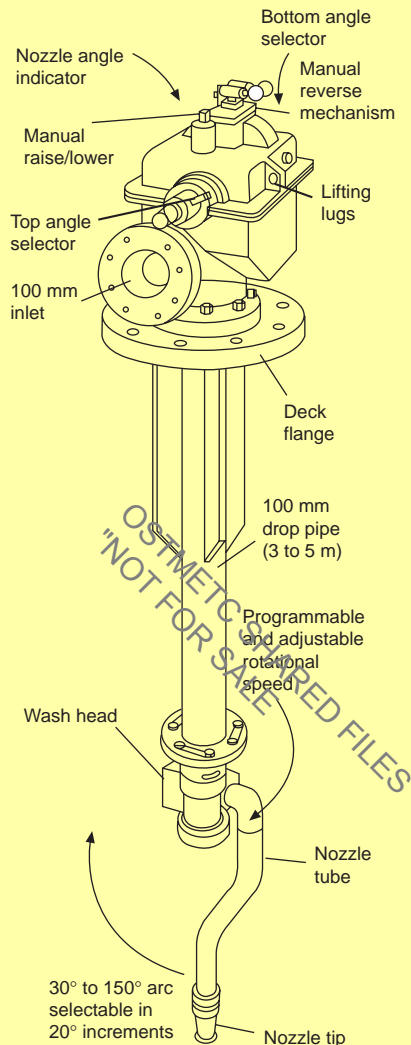

8. See all tank lids are closed and safe venting is being carried out.
9. Ensure oil loading into correct tanks.
10. Maintain state of heel and trim as required.
11. See that all oil hoses are supported and correctly secured.
12. Take care that electrically operated apparatus is used only if intrinsically safe.
13. Permit use of safe torches only.
14. See that means of access to accommodation is closed.
15. Ensure all scuppers plugged and drained.
16. Have fire-fighting equipment ready for immediate use.
17. Allow no unauthorised personnel aboard the vessel.
18. See that loading plan is observed and followed.
19. Have sufficient personnel available for topping-off purposes.
20. Ensure red light or 'B' flag is displayed.

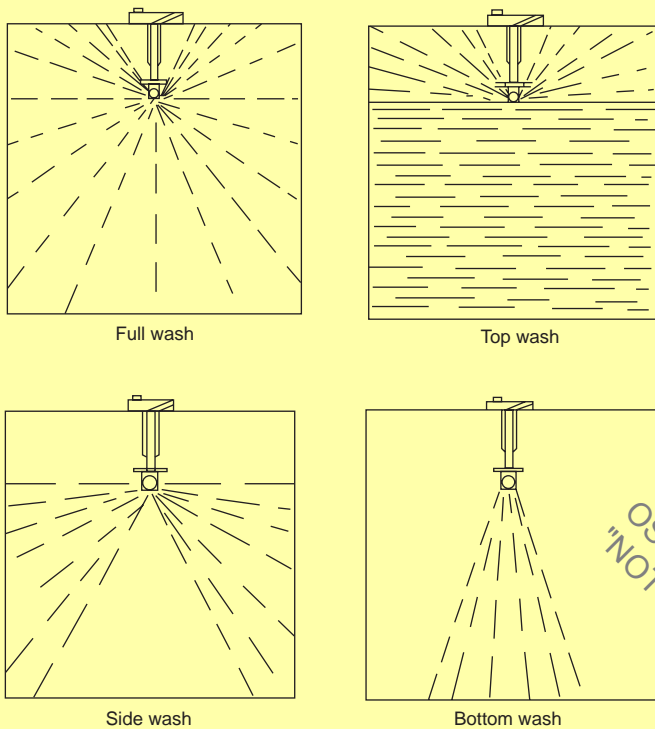

Figure 10.6 Washing cycle selection.

21. Have unused lines blanked off.
22. Make sure all company and port regulations are observed.
23. Establish efficient communications with shoreside personnel.
24. Keep deck log book up-to-date with current entries.
25. Maintain general deck watch, especially for changes in weather.
26. Check that inert gas system is isolated.
27. Avoid unnecessary pump-room entry. Have stand-by man available when entering.
28. See that drip trays are positioned.
29. Enforce no smoking regulations.
30. Forbid overboard discharges.

TANKER LAYOUT AND VENTILATION

Figure 10.7 gives a bird's eye view of tank layout, and Figures 10.8 to 10.10 cover ventilation.

HEALTH AND SAFETY

Accidents Due to Tanker Operations and Ship Design

Openings in the decks need to be covered and secured, which requires studs and nuts which project above deck level as much as 50 mm. These projections are usually obvious but during night-time operations, especially at sea, they can provide a serious danger, not only of stubbed toes, but of

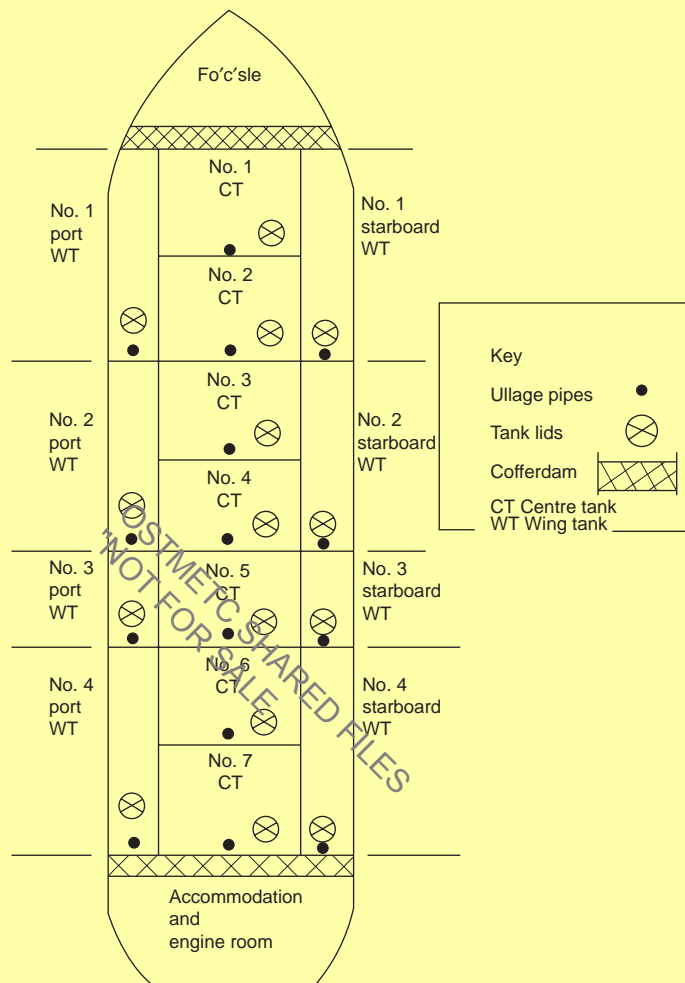

Figure 10.7 Ullage pipe and tank lid plan.

broken toes or even broken ankles and legs. During working hours, safety shoes should be worn, never loose fitting shoes or soft or open types of footwear.

Pipelines are ever-present on the decks of tankers; many are small and low and may be stepped over but many are large and their tops may be over 1 m above deck level. The larger pipelines will have walkways constructed across them at regular intervals and these should be used. To jump on top of pipelines to cross from one side of the deck to the other is extremely dangerous, as they are usually painted with gloss paint and falls between or from pipelines can cause all types of fractures and even death.

Overhead pipes and associated steelwork pose a very real threat and great care should be taken when passing under these. Safety helmets should be worn in the working environment.

Rarely does oil cargo find its way on to the tanker's decks but much of the equipment used on the tanker may require lubricating oil and the

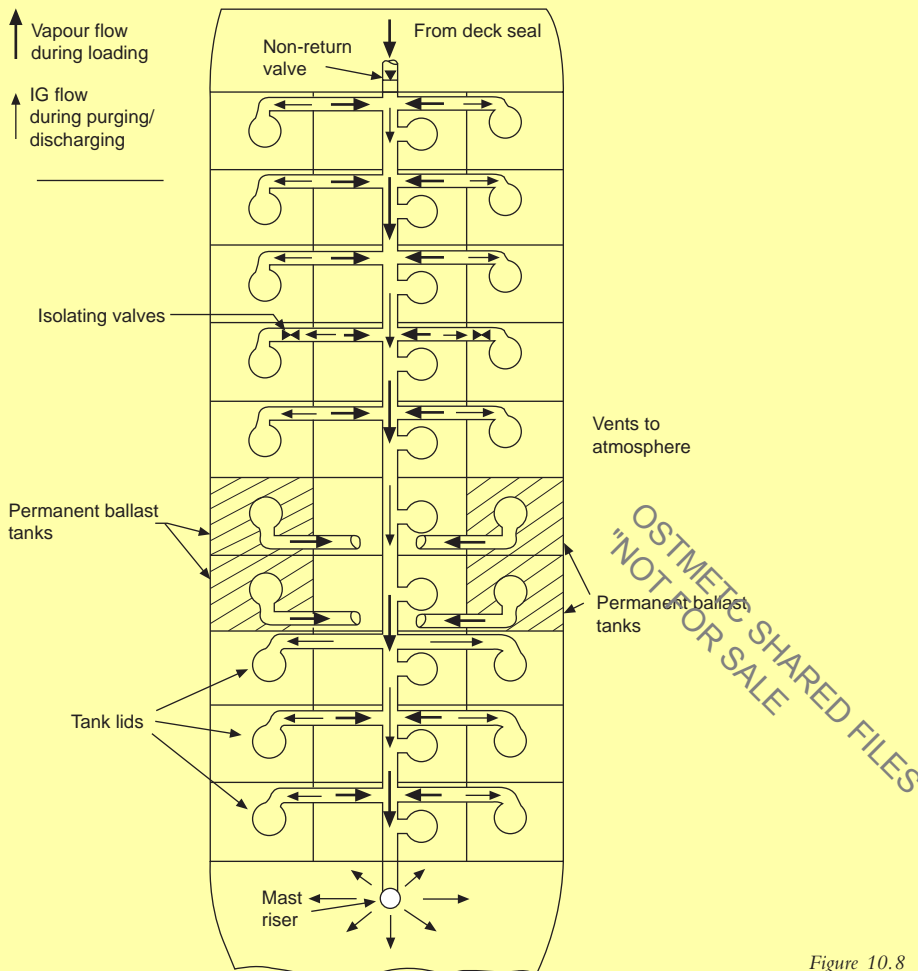

Figure 10.8 Gas venting system.

vessel may also use hydraulic oil for operating certain machinery. Oil leaks and seepages can form an almost invisible sheen on decks, which can be like ice. If water is present also, i.e. rain or sea water, then the situation becomes even more dangerous.

During operations on deck there is often the temptation to run from one area to another, especially if urged on by other persons. Running *must* be avoided as all the various dangers are accentuated for a running person. If you are being relied upon to complete an operation and you run to do it, and fall, there is a very good chance you will be at least unconscious; everyone is then in danger since the operation is out of immediate control. If you were walking and fell, it is far less likely that you would be totally disabled and, apart from a few second's delay, the operation could be completed.

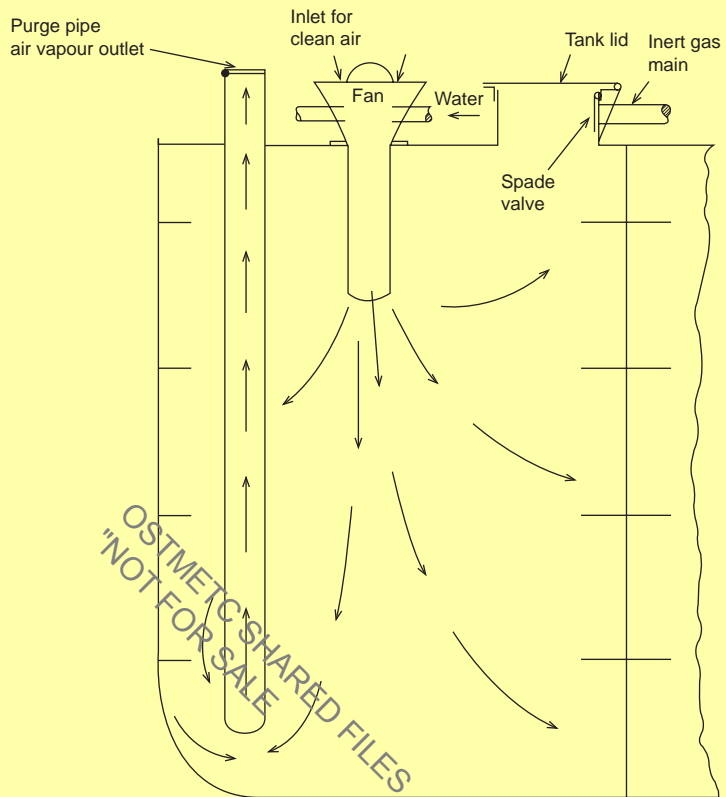

Figure 10.9 Cargo tank ventilation.

Inert Gas

Because inert gas is low in oxygen content, generally 5 per cent or less, it not only reduces fire hazards but also forms an asphyxiation risk. The human body is used to air containing 21 per cent oxygen and the average exhaled air is still in the region of 17 per cent oxygen; below 17 per cent content the air is no longer adequate for active life, and as the percentage falls the danger of death by asphyxiation rises. Where the presence of inert gas is suspected, the atmosphere should be tested for oxygen content before entry; if in doubt as to whether inert gas could or has been present, test anyway (see Figure 10.11). The compartment in question should also be continuously ventilated with fresh air.

Skin Contact with Hydrocarbons

Hydrocarbons are dangerous in many ways and in varying degrees, depending on their type. Certain hydrocarbons are thought to cause skin cancer if prolonged skin contact is maintained. Protective clothing such as gloves and boiler suit should be worn and kept clean. A dirty boiler suit is increasing skin contact time for any hydrocarbon with which it may be impregnated.

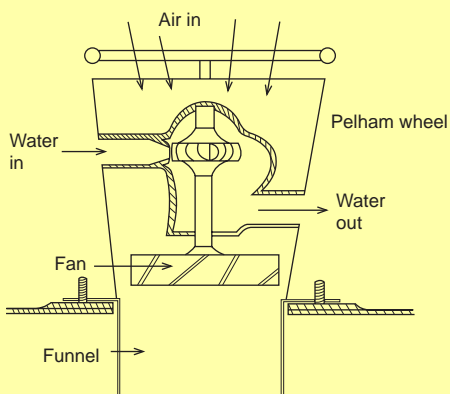

Figure 10.10 Gas-freeing (Axia) fan.

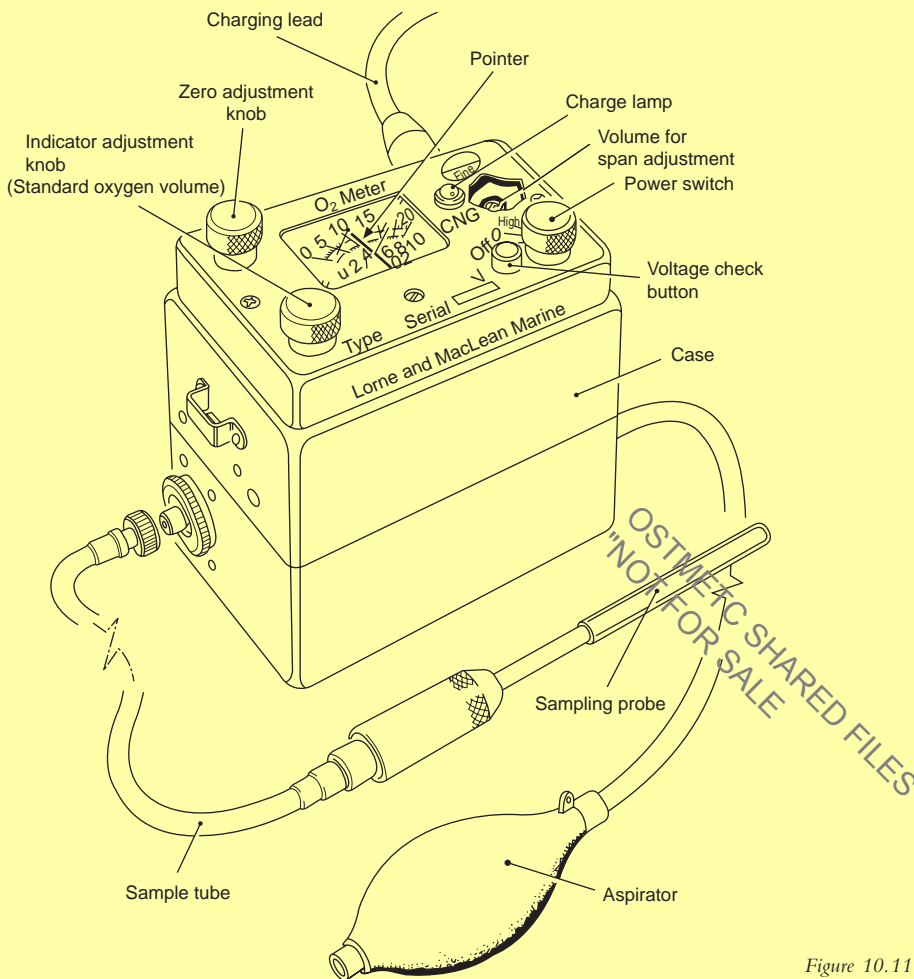

Figure 10.11 Oxygen test meter.

Inhalation and/or Swallowing of Hydrocarbons

Hydrocarbons and hydrocarbon vapours are, in varying degrees, toxic (poisonous). Hydrocarbon vapours are heavier than air and will displace air in a compartment from the bottom upwards, so that anyone entering a compartment will be at risk from asphyxiation through reduced oxygen levels and also poisoning from hydrocarbon toxicity. Whilst a re-entry into fresh air will remove the threat of asphyxiation, the toxic effect may remain. Certain hydrocarbons, e.g. of the aromatic family, can have a permanent cumulative effect and are particularly dangerous.

Where hydrocarbon gases are present, care must be taken to reduce the inhalation of these gases. The dangers due to swallowing hydrocarbons are also severe. Not only is long term toxicity of the body's cells a danger but immediate permanent damage to the throat, stomach and internal organs can also result.

Where a person is working in an atmosphere thought to be gas-free



Figure 10.12 Gas protection suit.

The gas protection suit shown here is designed for work in highly toxic atmospheres, e.g in cargo tanks etc. During such operations, the suit gives protection to the complete body. The suit is manufactured from extensible, abrasion-proof material, which is a highly durable polyester fabric, neoprene coated on one side. It is a one-piece suit, enabling the wearer to don quickly without assistance. Entry is effected through a diagonal aperture which is sealed with a gas-tight waterproof zip fastener. The sleeves are equipped with gas-tight cuffs or may be provided with gloves. The full vision facemask, with the universal, pneumatic seal and speech diaphragm, is bonded to the suit, allowing easy fitting for self-contained and airline breathing sets.

but starts to show symptoms similar to a drunken state, i.e. giggling, singing, lack of co-ordination, general fooling around etc. he is showing the first signs of hydrocarbon poisoning. A rescue procedure should be adopted immediately, so that the person can be removed safely from the poisonous atmosphere.

Protective Equipment

Compressed air breathing apparatus (CABA) comprises a face mask supplied with air from an air bottle carried by the user. In some cases the air may be supplied via a filter from a compressed air deck line (ALBA) but the user should also have a fully charged air bottle with him which will automatically continue to supply him with air should the deck air line supply fail. This provision is necessary to allow the person time to evacuate the space he is working in.

Automatic oxygen resuscitating equipment (Rescuepac) comprises oxygen bottles with automatic metering valves that will automatically supply a collapsed person with oxygen at the correct rate. This equipment is a powerful item of rescue equipment and should always be readily available in case of mishap when work is carried out in enclosed spaces.

Escape Sets and other Rescue Equipment

Escape sets are small CABA sets kept in positions where hydrocarbons may be released owing to operational failure, and they allow a person in that position sufficient air to effect an escape from the compartment. A typical position for an escape set would be at the bottom of a tanker's pump room.

Smoke helmets are mainly used for rescue and fire-fighting but may also be used for working purposes. The user wears a mask connected via a pipe to a bellows that must be situated in fresh air. The bellows may be mechanically operated but is more usually foot-operated. The pipe should be no longer than a length through which the user can draw air even if the bellows fails.

Lifelines and safety harnesses, the former steel cored and the latter made of terylene webbing, should be used where necessary.

Collapsed Person in Enclosed Space

Where any person or persons are working in an enclosed space, they must have a person outside the space whose sole responsibility is to watch them working to ensure their safety. If a person is seen to collapse in an enclosed space, the alarm must be raised immediately so that a rescue team with protective equipment (Figure 10.12), resuscitating equipment, lifelines and agreed communication systems can enter the space and carry the person to the nearest fresh air source (Figure 10.13). It is essential that the observer does not enter the compartment; he must raise the alarm and entry into the space must be made only by the rescue team with the correct equipment.

A gas detector is shown in Figure 10.14.

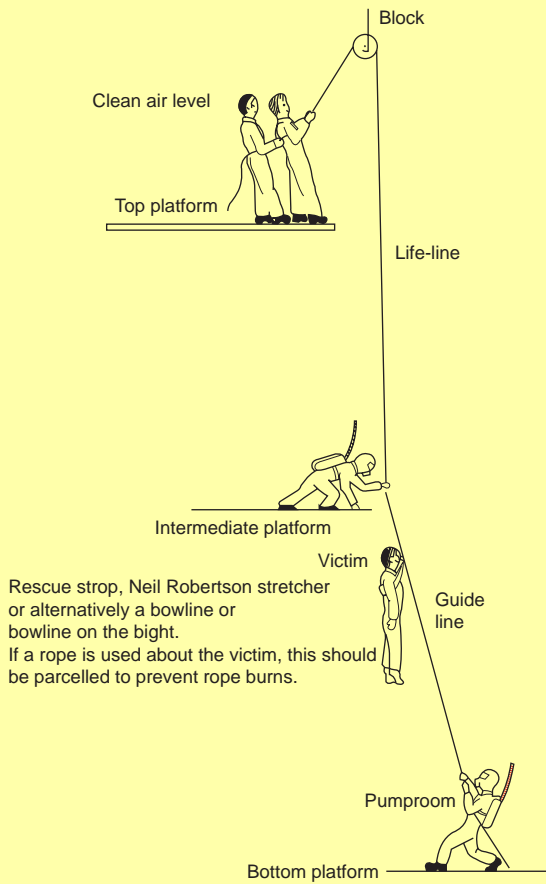

OSTMETC SHARED FILES
"NOT FOR SALE"

Figure 10.13 Pump-room rescue operation.

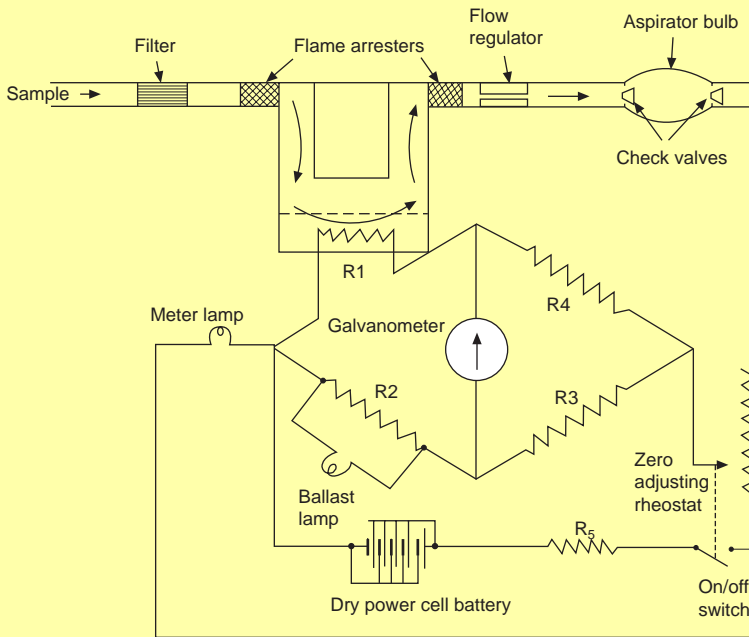

Figure 10.14 Combustion gas detector (catalytic filament type).

Guidelines for the Use of Marine Safety Card No. 1

Responsibility for safety, both at the time of entry of any tank or other enclosed space and during the entire operation, rests with the Master or responsible officer. This responsibility covers conditions of work for shore-based employees as well as for members of the ship's crew. The Master or officer makes sure that adequate steps have been taken to eliminate or control the hazards. He must also make sure that all personnel understand the nature of such hazards which remain, and the precautions to be followed.

Enclosed spaces include any tank, cargo space or compartment in which toxic inert, asphyxiating, flammable or other dangerous gases may accumulate, or oxygen may be deficient, such as:

1. Any space containing or having last contained combustible or flammable cargo or gases in bulk.
2. Any space containing or having last contained cargoes of a poisonous, corrosive or irritant nature.
3. Spaces in tankers immediately adjacent to the spaces referred to in (1) and (2) above.
4. Cargo spaces or other spaces that have been closed and/or unventilated for some time.
5. Storerooms or spaces containing noxious or harmful materials.
6. Spaces that have been fumigated.

The hazards inherent when working in an enclosed space can be avoided or overcome if the following rules are applied properly each and every time a space is entered:

1. Establish a definite system of pre-planning for enclosed space entry and a crew instruction programme.
2. Prepare the space for entry by physically isolating it, cleaning it to remove contaminants, and testing to ensure absence of such contaminants.
3. Use a checklist, backed up if necessary by a permit system. The checklist should only be issued to another crew member after the Master or responsible officer is satisfied personally with the precautions taken, personal protective equipment to be used, and procedures to be followed.

The Marine Safety Card No. 1 (Figure 10.15) serves as a method of reminding all concerned of recommended procedures and also as a checklist to ensure that all existing hazards are considered and evaluated, and, where necessary, the correct protective measures taken. It has been designed so that it may be used on board all types of ship, from the largest tanker to a small coastal vessel. Instructions and advice listed on the card are not intended in any way to take the place of other rules and recommendations on board the ship; it is intended to reinforce these. It may also be used in conjunction with a permit system, where one is employed.

It is recommended that the cards be issued only when the need for their use arises. When in use, the cards should be completed properly as instructed. Any relaxation is likely to result in diminishing respect for their use, with a resulting decline in the standards of safety achieved. In order to operate successfully, the Marine Safety Card must receive support from senior ship's personnel; the response of other crew members will obviously be influenced by this.

It may sometimes be necessary for a person to enter an enclosed space that is known to contain an unsafe atmosphere. This practice should only be allowed when it is essential or in an emergency. On no account should routine work be carried out under such conditions. Section 1 of the checklist should be completed by the Master or a responsible officer and the card should then be handed to the person who is to enter the space for completion of Section 2. Section 3 should be checked jointly by the responsible officer and the person who is to enter the space on every occasion that breathing apparatus is used.

It should be remembered that rescue and resuscitation equipment should be tested at the time of inspection and check.

The card is finished with a matt surface on the checklist side. It is recommended that a soft pencil is used to make the checks. After use the card should be cleaned with a rubber, tissue or damp cloth.

The card is issued by the General Council of British Shipping.

INERT GAS SYSTEM

The purpose of an inert gas system (Figure 10.16) is to blanket the surface of the cargo (or ballast) and prevent a mixture of air and hydrocarbons causing fire or explosion within the tank space. The gas is supplied by means of an 'inert gas generator' or extracted from 'boiler flue gases' taken from the main boiler uptakes. Remotely controlled 'butterfly valves' allow the extraction of the gas from port and starboard boiler uptakes before its entry via scrubbing tower, demister unit then water seal (Figure 10.17) before entering space.

The cooled, clean inert gas is drawn off from the scrubbing tower by conventional centrifugal fan units capable of delivering sufficient gas to replace cargo during discharge at the maximum pumping rate plus 25 per cent and to maintain a positive pressure at all times. The gas will enter the tank after passing through a 'deck-mounted water seal', which is specifically incorporated into the system to prevent hydrocarbon gases flowing back up the line. The deck water seal unit is fitted with a steam heater for operations in cold weather.

Additional safety features included in the system are a mechanically operated 'non-return valve' and a pressure/vacuum breaker fitted to prevent over or under pressurisation of the cargo tanks. (Alternatively the P/V breakers may be fitted individually to each tank.)

Venting of tanks during loading or when purging hydrocarbons is achieved by vent valves or masthead risers. As cargo levels rise during the process of loading the inert gas is vented into the atmosphere.

Figure 10.15 Marine Safety Card No. 1

MARINE SAFETY CARD No. 1

Entering Cargo Tanks, Pump Rooms, Fuel Tanks, Cofferdams, Duct Keels, Ballast Tanks of similar enclosed compartments.

General Precautions

Do not enter any enclosed space unless authorised by the Master or a responsible officer and only after all the appropriate safety checks listed on the reverse of this card have been carried out.

The atmosphere in any enclosed space may be incapable of supporting human life. It may be lacking in oxygen content and/or contain flammable or toxic gases. This also applies to tanks which have been inerted.

The master or a responsible officer **MUST** ensure that it is safe to enter the enclosed space by:

- (a) ensuring that the space has been thoroughly ventilated by natural or mechanical means; and
- (b) where suitable instruments are available, by testing the atmosphere of the space at different levels for oxygen deficiency and/or harmful vapour; and
- (c) where there is any doubt as to the adequacy of ventilation/testing before entry, by requiring breathing apparatus to be worn by all persons entering the space.

WARNING

Where it is known that the atmosphere in an enclosed space is unsafe it should only be entered when it is essential or in an emergency. All the safety checks on the reverse side of this card should then be carried out before entry and breathing apparatus must be worn.

Protective Equipment and Clothing

It is important that all those entering enclosed spaces wear suitable clothing and, that they make use of protective equipment that may be provided on board for their safety. Access ladders and surfaces within the space may be slippery and suitable footwear should be worn. Safety helmets protect against falling objects and, in a confined space, against bumps. Loose clothing, which is likely to catch against obstructions, should be avoided. Additional precautions are necessary where there is a risk of contact with harmful chemicals. Safety harnesses/belts and lifelines should be worn and used where there is any danger of falling from a height.

There may be additional safety instructions on board your ship, make sure that you know them.

Further information on safe entry into enclosed spaces is contained in the Code of Safe Working Practices for the Safety of Merchant Seamen and the ICS Tanker Safety Guides.

Issued by the General Council of British Shipping,
30–32 St Mary Axe, London, England EC3A 8ET.

© 1975

SAFETY CHECK LIST

Before entering any enclosed space all the appropriate safety checks listed on this card must be carried out by the master or responsible officer and by the person who is to enter the space.

N.B. For routine entrance of cargo pump rooms only those items shown in red are required to be checked.

SECTION 1

To be checked by the master or responsible officer

- 1.1 Has the space been thoroughly ventilated and, where testing equipment is available, has the space been tested and found safe for entry ?
- 1.2 Have arrangements been made to continue ventilation during occupancy of the space and at intervals during breaks ?
- 1.3 Are rescue and resuscitation equipment available for immediate use beside the compartment entrance ?
- 1.4 Have arrangements been made for a responsible person to be in constant attendance at the entrance to the space ?
- 1.5 Has a system of communication between the person at the entrance and those in the space been agreed ?
- 1.6 Is access and illumination adequate ?
- 1.7 Are portable lights or other equipment to be used of an approved type?

When the necessary safety precautions in SECTION 1 have been taken, this card should be handed to the person who is to enter the space for completion.

SECTION 2

To be checked by the person who is to enter the space

- 2.1 Have instructions or permission been given by the master or a responsible officer to enter the enclosed tank or compartment ?
- 2.2 Has SECTION 1 been completed as necessary ?
- 2.3 Are you aware you should leave the space immediately in the event of failure of the ventilation system ?
- 2.4 Do you understand the arrangements made for communication between yourself and the responsible person in attendance at the entrance to the space ?

SECTION 3

Where breathing apparatus is to be used this section must be checked jointly by the responsible officer and the person who is to enter the space.

- 3.1 Are you familiar with the apparatus to be used ?
- 3.2 Has the apparatus been tested as follows ?
 - (i) Gauge and capacity of air supply
 - (ii) Low pressure audible alarm
 - (iii) Face mask – air supply and tightness
- 3.3 Has the means of communication been tested and emergency signals agreed ?

Where instructions have been given that a responsible person be in attendance at the entrance to the compartment, the person entering the space should show their completed card to that person before entering. Entry should then only be permitted provided all the appropriate questions have been correctly checked

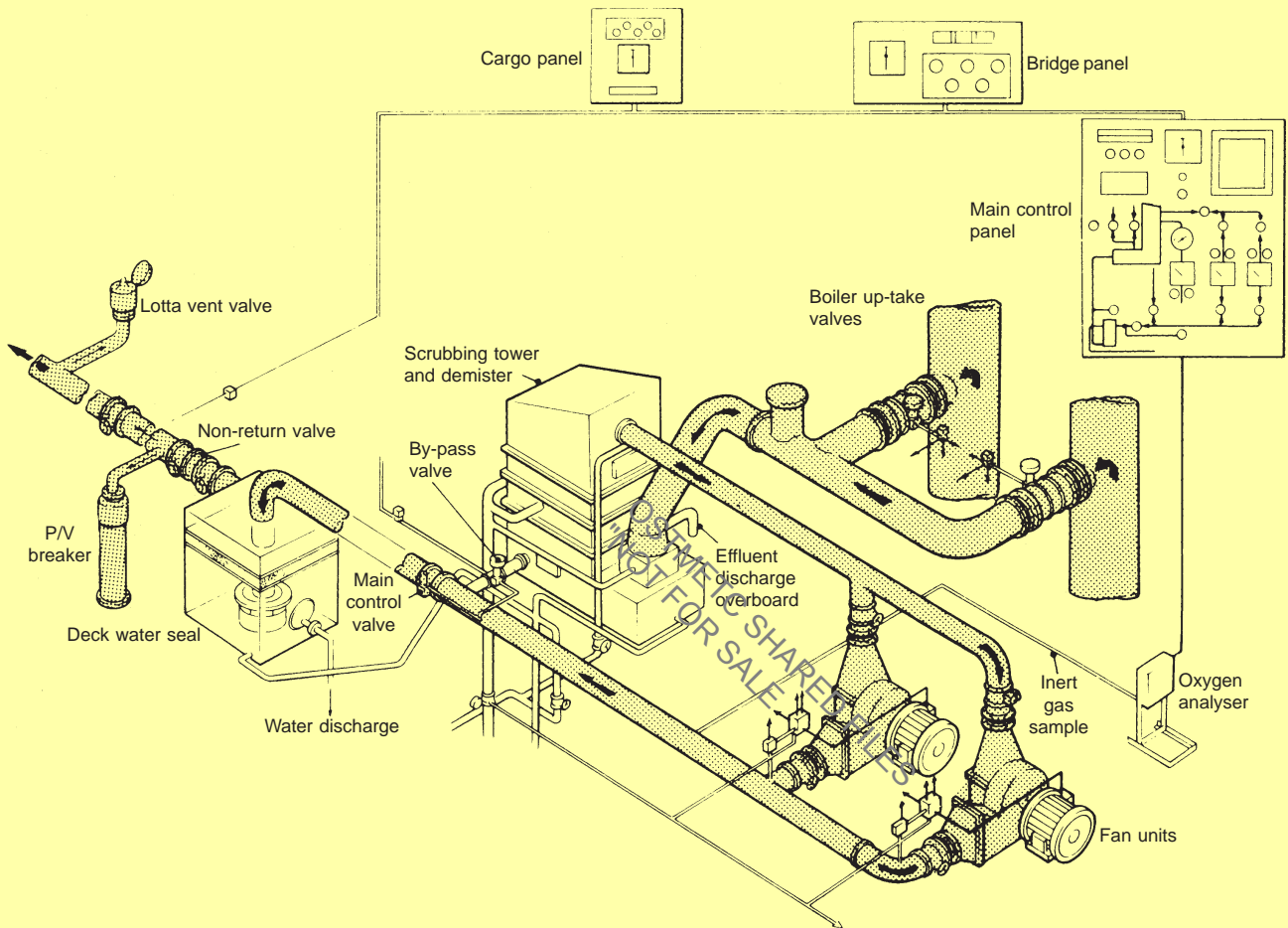
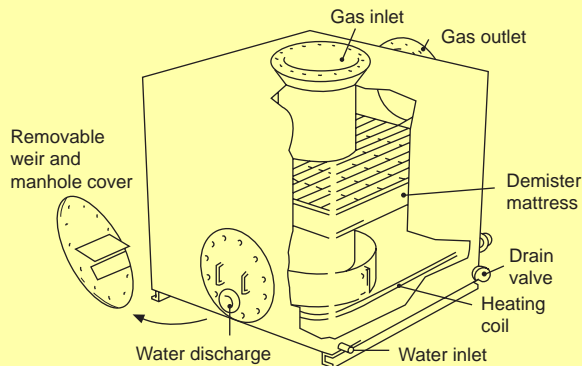

Figure 10.16 Inert gas system.

Figure 10.17 Deck mounted water seal.

This deck mounted water seal prevents hydrocarbon gases flowing back to the uptakes. This safety feature is additional to the seal in the bottom of the scrubber and the gas non-return valve in the inert deck main. Sea water is used for the water seal and it is continuously pumped into the base at 4 tons/hour, the correct level being maintained by a weir. A coarse polypropylene demister mattress is fitted above the water seal to remove any water carry-over. All internal surfaces are ebonite rubber lined, cured in situ.



Composition of Boiler Flue Gases

The average composition of flue gases employed as inert gases and obtained from main or auxiliary boilers is as follows: CO₂ 13 per cent, O₂ 4 per cent, SO₄ 0.3 per cent, the remaining percentage being made up of nitrogen and water vapour. Such a mixture will not support combustion, and is therefore suitable for use as an inert gas once it is cooled and cleaned.

Advantages

1. Safety – risk of fire and/or explosion reduced.
2. Reduced corrosion – tank corrosion is inhibited by the low oxygen content of the gas.
3. Faster cargo discharge – the increased tank pressure created during the period of discharge by the introduction of the inert gas into the tank speeds up the discharge operation.
4. Tank washing time is reduced because it is possible to wash with high-capacity fixed guns in an inert atmosphere. Crude oil washing (COW) is also possible under these conditions.

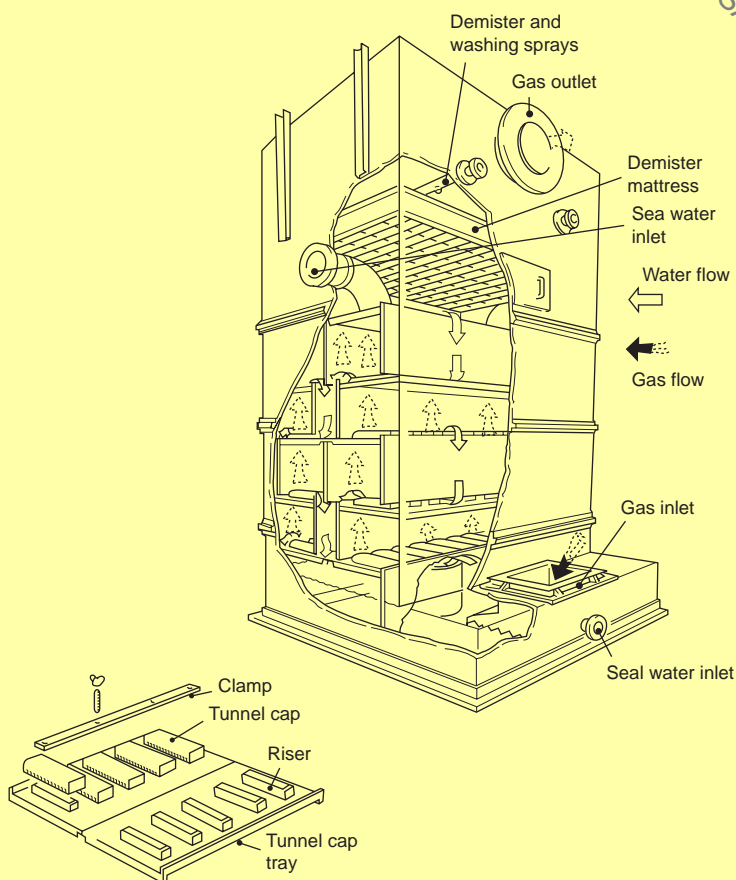

Figure 10.18 Scrubbing tower and demister.

The purpose of the scrubber is to cool and remove unwanted elements from the boiler flue gas. Water is introduced from the top of the scrubber, while the gas enters via a water seal at the bottom. This water seal also serves to cool the gas as it enters the tower. Up to 98 per cent of acids (SO₂) are removed under normal operational conditions.

5. Fresh air purging of the tanks – the system can provide large volumes of fresh air to cargo tanks very quickly, which is beneficial for maintenance and tank inspections.
6. Cheap and readily supplied (funnel exhaust gases).
7. Compatible for use with certain chemicals which react with oxygen.

Disadvantages

1. Installation cost is high initially, with additional expense incurred for general maintenance.
2. Danger to personnel due to the lack of oxygen within the tank.
3. Reduced visibility inside the tanks.
4. Additional cost of an inert gas generator required for use when main engines are not in use, e.g. when in port.
5. Danger of flammable gases returning towards the boiler if water seal and non-return valve are not properly maintained.
6. Improved purity required in inert gases for use with chemicals, i.e. need for nitrogen, with the additional expense that this purchase incurs.

MOORING LARGE TANKERS

Anchoring

The requirements of large tankers in the way of deeper water and heavier anchor equipment than other vessels have become obvious areas of consideration since the arrival of the first 100,000 DWT vessel. Now much larger tonnage, such as the VLCC and the ULCC type vessels, have appeared, further consideration is warranted.

The depth of tanker anchorages throughout the world usually range from 20 to 30 fathoms (36.6–55 m). The minimum amount of cable that a large vessel may expect to use must be considered about six times the depth of water, i.e. 120 to 180 fathoms (220–330 m), provided all other conditions are favourable. Since the length of chain cable required by the Classification Society is 351 m for the largest ships, it can be seen why Masters are reluctant to use anchors.

In all fairness to the shipowners the majority have equipped their vessels with adequate reserves of cable, and it is not uncommon for vessels to carry 15 shackles (450 m) chain cable on each anchor. If conditions were such that ten times the depth of water would be an appropriate amount of cable to use, this would limit the vessel to anchoring inside depths of 45 m.

Having considered the amount of cable to be used in anchoring, mariners should look at any weak links in the system. They do exist, and are encountered usually at the windlass with the braking system, or at the anchor itself with respect to its holding power.

Most of the information regarding the anchor arrangements for large vessels has come from experience gained on smaller vessels. In many respects the experience has been transferable, but in other areas new concepts of safe handling have had to be developed. Controlling the

speed of a running cable by use of a band brake on the windlass is no longer acceptable. The momentum achieved, say, by a 15 tonne anchor with added weight of cable, free running, is too great to handle.

In order to control the great weights of anchor and chain, the chain velocity and the consequent friction, hydraulically operated braking systems have now been devised. The modern designs are such that the faster the cable runs, the greater the pressure created on the braking system. Other commercially available systems employ disc brakes and limit switches governing the speed of the windlass.

Types of Anchor

There are many types of anchor presently in use aboard most kinds of larger vessel, not just large tankers. Various weights of anchors with different sizes of cable have been tried and tested in all conditions over the last few years. The AC 14 anchor, popular not only with warships but also with large passenger liners, would appear to be the most suitable to combat the kinetic energy of, say, a ULCC moving slowly over the ground.

Seafarers engaged in the mooring of large vessels will no doubt be aware of the many variables which could affect the operation before the 'brought up' position is reached. The holding ground, weight of chain and the weight of the anchor itself will influence the time that the anchor is dragging before it starts to hold, assuming that the anchor does not become snagged or hung up on a rocky bottom.

The old idea that the amount of cable paid out is what holds the vessel is still true for VLCCs and ULCCs, but vessels fitted with an anchor of high holding power will have a distinct advantage. Masters and berthing pilots should be wary once the anchor has held, especially one of good holding power, of the possibility of parting the chain cable by excessive ship-handling movements. The problem is accentuated when the external uncontrollable forces of current, wave motion, and wind are present in a manoeuvring operation.

If the berthing situation is one where anchors may be used, full consideration of their use should be made before the operation is executed. Prudent use of tugs' mooring lines, bow thrust units, main engine propulsion, and an efficient mooring launch will undoubtedly help in ship-handling operations with this type of vessel.

Mooring Systems

Offshore terminals where tankers of all sizes are required to load and discharge via single point moorings (SPMs) are now an accepted fact of the oil tanker trade. Complete rope assemblies for securing to an SPM are commercially available, and they are made to provide not only maximum strength but also a high energy absorption capacity to counteract heavy and repeated loadings. The general design may vary to take chafe into account either at the buoy end or at the vessel's 'pick up' end. Vessels are very often fitted with purpose-built bow stoppers for accepting the fairlead chains. Failing this, tankers are secured by nylon braidline strops

or flexible (6 × 36) galvanised steel wires turned directly on to bits (see Figure 10.19).

OIL POLLUTION

This subject is presented under the following headings:

1. Loading/discharging of bulk oil.
2. Compulsory insurance for vessels carrying persistent oil in bulk.
3. Reception facilities for oily waste.
4. Reporting of pollution incidents.
5. Penalties and offences with regard to oil pollution incidents.
6. Prevention of oil pollution.
7. The prohibition of oil discharges into the sea from ships.
8. Resumé of existing oil pollution regulations and what can be expected for the future.

Loading and Discharge of Bulk Oil

The Master of any vessel is finally responsible for the correct loading and safe carriage of his cargo. However, it is accepted practice that his responsibilities are delegated to ships' officers, the 'chief officer' being generally given that of cargo operations officer for the vessel.

Loading of cargoes is expected to comply with all provisions of the stability booklet. The slack tanks should be noted and kept below the limiting number. Free surface build-up in slack tanks in the past has sometimes made the vessel 'unstable' while loading or discharging. Should any abnormal list develop during loading, oil cargo may overflow. This

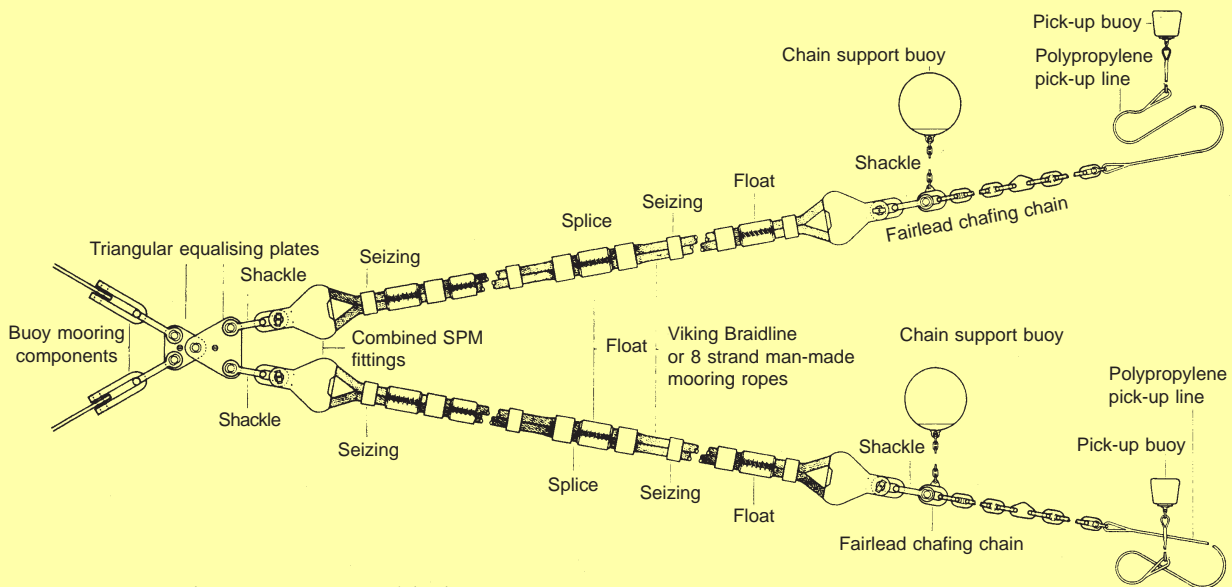

Figure 10.19 Typical mooring system used by buoy operators in a conventional single point mooring.

undesirable situation could be exacerbated by an imbalance in the quantity of water in ballast tanks, the combined effect of free surface in too many tanks and the added free surface effect from partly filled fresh water and ballast tanks.

Cargo officers will require the following information when about to load bulk oil:

1. Cargo specifications and special characteristics, e.g. lead content.
2. Loading temperatures, together with flashpoints and specific gravity of oil.
3. Nominated quantities and tank order of loading.
4. Maximum shore loading rate and maximum back pressures at the manifold.
5. Communication system and emergency stop arrangements.
6. Number of hoses to be employed, with their respective size for each grade of oil.
7. Loadline figures for bunkers, boiler feed, stores etc. to ensure that the vessel's draught conforms to loadline regulations when passing through the various 'zones'. (These calculations will determine the quantity of cargo loaded.)

The terminal will require the following information:

1. Types of previous cargoes carried, and the method of tank cleaning employed.
2. Maximum loading rate and topping off rate that the vessel can handle.
3. Maximum back pressures at the manifold.
4. Cargo loading plan, tank disposition and cargo quantities.
5. Order of loading or discharging.
6. Quantity of ballast for discharge and quantity of slops (oily waste), together with their disposition.
7. Method of venting. Precautions against static.
8. Cargo specifications and ballast time for the vessel.

The cargo officer should take the following precautions against accidental oil spillage or leakage:

1. See moorings are tended throughout operations, and hose lengths sufficient to allow for ranging. Close off all valves not in use.
2. Carry out regular checks on cargo tanks, especially during the topping off period.
3. Plug scuppers before starting, draining off any excess water.
4. Provide drip trays at the manifold.
5. Blank off all lines and connections not in use.
6. Draw up contingency plans in the event of spillage.

In the event of spillage, e.g. a burst hose length, proceed as follows:

1. Stop all cargo operations. Sound the alarm.
2. Prevent oil or vapour entering the engine room.
3. Inform harbour authority, terminal manager, and adjacent shipping.

SOPEP – Ships Oil Pollution Emergency Plan,
Ref. MGN 110.

4. Enter details of the incident into the oil record book.
5. Close access doors and shut down ventilation systems.
6. Consult spillage contingency plans (SOPEP).

The following pump-room precautions should be taken:

1. Avoid loading through the pump room.
2. Ensure that all drain plugs and strainer covers etc. are secure before loading.
3. Inspect pump glands regularly for leakage and the overheating of bearings.
4. Test level alarms before they are employed.

Transfer of oil from a vessel while in port cannot be undertaken before the following procedure is carried out:

1. Written permission must be obtained from the harbourmaster. In some ports the vessel may have to be moved to a special berth before permission will be granted.
2. Port by-laws must be observed at all times.
3. All overboard discharges must be secured when connected to oil transfer pumps before transferring takes place.

Compulsory Insurance

Insurance regulations are laid down by the International Convention on Civil Liability for Oil Pollution Damage, 1969, which came into force from 19 June, 1975, and the Merchant Shipping Act (Oil Pollution), 1971, as amended by section 9 of the Merchant Shipping Act, 1974. The regulations state that a vessel of whatever registry, when carrying more than 2000 tons of persistent oil, shall not be allowed to enter or leave a port in the United Kingdom without a certificate of insurance (or other financial security). This also applies to UK ships entering any other country's territorial waters with more than 2000 tons of persistent oil, in bulk, as cargo.

Non-persistent oils include motor spirit, kerosene and the lightest fractions of the refining process. If they were to be deposited close to a coastline they might contribute to pollution of the beach areas, but if deposited at a reasonable distance out at sea they evaporate or otherwise disappear.

Animal and vegetable oils are assimilated by the sea water or physically by animal life within the sea water.

Whereas a *persistent oil* will not break down with sea water, and remains for indefinite periods floating on the surface. The mineral oil derivatives most likely to cause contamination were fuel oils and waxy crude oil waste, together with diesel. These particular grades when discharged at sea did not dissipate completely, but left a 'film' over the surface which gradually coalesced to form thick rubbery lumps of lower specific gravity, than that of sea water. The lumps floated, as with tide, winds and currents.

Persistent and non-persistent oils are graded by the authorities with

relation to the nuisance value of the type of oil when mixed with sea water.

Certificates are issued by the government authority of the country whose flag the vessel sails under. In the United Kingdom the certifying authority is the Department of Trade, Insurance Division. Satisfactory evidence must be produced to the certifying authority for the issue of the certificate. Non-compliance with the regulations for obtaining a certificate of insurance (or being covered by financial security) may cause the vessel to be detained or fined or both, when the fine would not exceed £35,000.

Reception Facilities for Slops

Dirty ballast and oily waste are the main constituents of slops and the main problem in pollution control. From the early days of pollution control it has been the responsibility of the oil companies or the tankers themselves to solve the problem of dealing with waste products.

Many ports have now established reception facilities for slops, but there are as many without such means. To offset the immediate problem, tankers allocate one or more of their cargo tanks for the storage of waste products. This temporary storage lasts only until the vessel is able to pump the contents of the 'slop tank' ashore into purpose-built receptacles.

During tank washing procedures, the oily waste rises to the surface, leaving clean (relatively oil-free) water underneath. The pumping of this water via an oily water separator certainly eases and reduces the problems of volume in the slop tanks. The problems of wax and sludge remain and have to be handled by shoreside facilities.

Waste may be classified as follows:

- (a) Dirty ballast water.
- (b) Tank washing residues.
- (c) Sludge and scale (from tank-cleaning operations).
- (d) Oily mixtures contaminated by chemical cleansing agents.
- (e) Contaminated bilge water.
- (f) Sludge from purification of fuel or lubricating oils.

Signatories to the Convention for the Prevention of Oil Pollution have established a reporting scheme whereby Masters of vessels may enter a report on port facilities. Reports on reception facilities for oily waste products should be submitted to the shipowner and then forwarded to the national administration (in the UK the Department of Trade). MGN 82 (M + F) gives further details.

Reporting of Pollution Incidents

Oil spillage reporting arrangements have been practised by UK registered vessels for some considerable time but the Marine Environment Protection Committee of IMO has recently applied the reporting scheme to cover spills of substances other than oils.

Masters and other observers should report any of the following:

1. An accident in which actual spillage of oil or other harmful substance occurs, or may occur.
2. Any spillage of oil or other harmful substance observed at sea.
3. Any vessel seen discharging oil in contravention of the International Convention for the Prevention of Pollution Regulations 1983–85.

Such incidents or slicks which may affect coastlines or neighbouring states should be reported to the nearest coast radio station. In the United Kingdom reports should be directed to the coastguards, via the coast radio station. Pollution reports should be made as quickly as possible and in plain language. To the Marine Pollution Control Unit (MPCU) of the MCA.

They should contain the following information:

- (a) Name of the reporting ship.
- (b) Name of the ship, if known, causing the pollution (whether or not this is the reporting vessel).
- (c) Time and date of the incident or observation.
- (d) Position of the incident or observation.
- (e) Identity of the substance, if known.
- (f) Quantity of spill (known or estimated)
- (g) Wind and sea conditions.

Penalties and Offences

Under the United Kingdom Merchant Shipping Act, 1979, and the Merchant Shipping (Oil Pollution) Act 1971, as amended, the owner or Master of a ship from which oil has been illegally discharged into the sea is liable, on summary conviction, to a fine not exceeding £50,000, or on conviction on indictment to a fine.

The shipowner can limit and escape liability if he is not at fault and can prove that the discharge was:

- (a) Through an act of war or natural phenomenon beyond his control.
- (b) Any other person, causing damage or intending to cause damage, who is not employed by the company or an agent of the company, was responsible. (This covers the shipowner against terrorist and such like activity.)
- (c) Due to any authority not maintaining navigational equipment to the proper specifications.

The owner can limit liability to approximately £56 per ton, of the vessel's tonnage or approximately £5,800,000, whichever is the least. Should the shipowner be at fault, then he cannot limit his liability.

For many offences under the Merchant Shipping Act the fines incurred range from £50 to £1000 on summary conviction of the offence, together with an unlimited fine and imprisonment on conviction on indictment.

As regards insurance, the carriage of more than 2000 tons of persistent oil in bulk as cargo without valid insurance or other valid financial

NB. Since the ExxonValdez pollution incident in Alaska (1989) ship owners have not been allowed to limit liability in the event of oil pollution accidents.

security is an offence. The penalty on summary conviction is a fine not exceeding £35,000 and possible detention of the ship.

It is also an offence if the Master fails to produce a certificate of insurance. He is liable on summary conviction to a fine not exceeding £400.

Should a vessel fail to carry a certificate of insurance, then the Master of the vessel is liable on summary conviction to a fine not exceeding £400.

If a person directed by the regulations fails to deliver a certificate of insurance (surrender the certificate to the correct authority), then that person is liable on summary conviction to a fine not exceeding £200.

Regarding the movement of oil, vessels are required to be fitted with items of equipment that prevent the discharge of oil into the sea. Such equipment must comply with the standards specified in the Oil in Navigable Waters Act. Should these provisions be contravened the owner or the Master of that vessel is guilty of an offence. The penalty on summary conviction is a fine not exceeding £1000, or on indictment to a fine.

Transferring oil at night may be an offence. No oil should be transferred at night between sunset and sunrise to or from a vessel in any harbour in the United Kingdom unless the requisite notice has been given in accordance with the Oil Pollution Act, or the transfer is for the purposes of the fire brigade. On summary conviction the offender is liable to a fine not exceeding £100.

Failure to report a discharge of oil is an offence. It is the duty of the owner, Master or occupier of the land about which a discharge of oil occurs to report such discharge. Any person so concerned who fails to make such a report is guilty of an offence, and on summary conviction to a fine not exceeding £200.

Failure to comply with instructions from the Secretary of State, or his designated agent to avoid pollution from the result of a shipping casualty is an offence. Should any obstruction occur, the person causing that obstruction, on summary conviction may be subject to a fine not exceeding £50,000, or on conviction on indictment to a fine.

Failing to carry an oil record book, as required by the regulations, is an offence, and the owner or Master shall be liable to a fine not exceeding £500 on summary conviction.

Failure to keep proper records is an offence, subject on summary conviction to a fine not exceeding £500 for the person who is responsible.

Deliberately making a false or misleading entry in the oil record book or in any other similar records is an offence. The penalty on summary conviction is a fine not exceeding £500 or imprisonment for a term not exceeding six months, or both, or on conviction on indictment to a fine or to imprisonment for a term not exceeding two years or both.

Failure to produce the oil record book is an offence, subject on summary conviction to a fine not exceeding £10.

Any person who obstructs the duty of an inspector who is acting with the power of inspection concerning oil records, is guilty of an offence. He is liable on summary conviction to a fine not exceeding £100.

It is a requirement for records to be retained for a minimum period of two years by the authority designated by the regulations. If those responsible for the custody of records fail in this duty, they may be liable on summary conviction to a fine not exceeding £500.

Prevention of oil Pollution

Regulations from IMO now specify the installation of oily water separators aboard all non-tanker type vessels over 400 gross tons. There are many types of oily water separators available, each providing clean water discharge well below the 15 parts per million of oil in water requirement.

Depending on size, capacity will vary with the model being used, from 0.5 cu.m per hour up to 60 cu.m per hour. The primary purpose of oily water separators is to prevent pollution, but the value of the recovered oil should not be overlooked.

The *Torrey Canyon* disaster in March 1967 demonstrated the need for pollution control and increased research into prevention methods. It also highlighted the need for new ideas and methods of containment in pollution incidents.

The enclosure of any spillage by use of some form of barrier was widely investigated and subsequently tried. Some degree of success was achieved when small spillages were encountered and good weather prevailed at the time. However, over large areas the time required to establish the barrier was found to be excessive, and barrier equipment needed to encircle a large area would not always be readily available. The controlling factor in the containment of oil spillage by a floating barrier is undoubtedly the weather.

Strong detergents have been tried on many occasions in 'clean-up operations' after spillage has occurred. The main disadvantage of this method is that the detergent used must be effective in breaking up the oily substance quickly, but very few achieve this result. Large quantities of detergent are required and the cost of using this method is high. Difficulties also arise with dispensing detergent over a wide area and achieving full coverage.

One would think, after the many lessons that have been given, it would be found cheaper and more practical to train personnel and equip modern ships to prevent pollution occurring in the first place. However, the consequences of collision or accident will always need to be dealt with by external agencies.

Prohibition of Oil Discharge into the Sea from Ships

With certain exceptions no discharge of oil into the sea may take place within the territorial waters of the United Kingdom. This applies to ships of any flag. It is also forbidden for ships registered in the United Kingdom to discharge oil into the sea anywhere else in the world.

Notable exceptions are as follows:

- (a) Vessels of less than 80 gross registered tons may discharge from their bilges while they are in UK territorial waters a mixture in

which the only oil is lubricating oil which has drained or leaked from machinery spaces.

- (b) A harbour authority may appoint a place within its jurisdiction where ballast water of vessels in which a cargo of petroleum spirit (as defined by regulations) has been carried may be discharged into the waters of the harbour, at such times, and subject to such conditions, as the authority may determine.

In the event of proceedings being brought against the owner or Master of a vessel, special defences may apply in the following circumstances:

1. If it can be proved that any discharge was made for the purpose of securing the safety of any vessel, of preventing damage to any vessel or cargo, or of saving life.
2. If it can be proved that the discharge occurred in consequence of damage to the vessel, and that as soon as practicable after the damage occurred all reasonable steps were taken for preventing or (if it could not be prevented) for stopping or reducing the escape.
3. If it can be proved that the escaped oil or mixture was caused by reason of leakage, that neither the leakage nor any delay in discovering it was due to any want of reasonable care, and that as soon as practicable after the escape was discovered all reasonable steps were taken for stopping or reducing the leak.

Resumé of Oil Pollution Regulations

The question of pollution has become politically sensitive not just in the marine field but also in the atomic field. The protection of the environment has become the concern of all responsible persons, and rightly so. However, society demands improvements in living standards, and these demands have created their related problems, e.g. pollution.

Without doubt control of oily water mixtures, garbage nuclear waste etc. will be tightened up so that no pollution of the environment will be allowed to take place. This situation will be a long time coming but it is by no means out of reach.

It must be expected that existing legislation, namely the Oil in Navigable Waters Act and Prevention of Oil Pollution Act, will be reviewed and tighter control with stiffer penalties for offenders become the order of the day. More countries will become signatories of the 1954 Convention for the Prevention of Oil Pollution and eventually the responsibility for preventing pollution will be accepted by all nations.

In 1973 a second convention was adopted at a conference in London, attended by 71 nations. The regulations set down, and subsequently reviewed in 1978, are known as Marpol regulations, for which the target date for enforcement was June 1981. (Additional amendments to Marpol 1988, 1991, 1995. Inclusive of garbage regulations.)

The following are some of the main points:

1. Oil means crude, fuel oil, lubricating oil, petrol, kerosene, naphtha etc.

SHIPHANDLING

2. Tonnages are gross registered tons and *not* deadweight tonnes.
3. The regulations will apply immediately to new ships, i.e. vessels delivered to owners after 31 December, 1979, and vessels undergoing major conversion completed after 31 December, 1979, and will apply to existing ships by 2 October 1986.
4. All ships of 400 GRT or more, if less than 10,000 GRT, should be fitted with an oily water separator or filter, achieving not more than 100 parts per million; and if 10,000 GRT or more should be fitted as above plus the following:
 - (a) a monitoring system which comes into operation when there is any discharge of effluent, e.g. fluid left after settling for a number of days.
 - (b) a control system such that any discharge of oily mixture is automatically stopped when the oil content of the effluent exceeds 100 ppm, plus an audio visual alarm.

Failure of either monitoring or control systems would cause the immediate stopping of the operation, the event being noted in the oil record book. Existing ships may manually stop discharge when the ppm alarm is activated.

5. If the ship chooses not to have a monitoring and control system, she shall be fitted with an oily water separator whose effluent is not more than 100 ppm, and pass this effluent to an oil filter system that will produce an effluent whose oil content does not exceed 15 ppm and is fitted with an alarm to indicate when this level cannot be maintained.

Even when this degree of cleanliness is achieved, the ship must be more than 12 miles from land, or be proceeding en route, i.e. she cannot leave a dock to dump then return to port. Every ship is to be provided with tanks of adequate capacity to receive oil residues (sludge) from purification processes (oil leakages etc.) until such time as it can be received ashore.

Pollution References

'M' NOTICES (CURRENT - SEPTEMBER 2000)

- 700 Oil pollution prevention on tankers, separation of cargo oil piping system from the sea.
- 1196 Marine pollution - manual on oil pollution.
- 1197 The Merchant Shipping (Prevention of oil pollution) Regulations, 1983 - Additional recording and documentation for oil record books.
- 1273 Control of pollution by noxious liquid substances in bulk-implementation of Annex II to MARPOL 1973/1978 (with amendment)
- 1374 Oil pollution - compulsory insurance.
- 1438 The Merchant Shipping (Control of Pollution by Noxious Liquid Substances in Bulk) (Amended) Regulations, 1990.
- 1447 The merchant Shipping (Control of Pollution by Noxious Liquid Substances in Bulk) Regulations, 1987 (as amended), Surveys and related matters.
- 1577 Extension of strict liability of shipowners for oil pollution damage.
- 1589 The Merchant Shipping (IBC code) (BCH code) Regulations, 1994 and the (Control of Pollution by Noxious Substances in Bulk) (Amendment) Regulations, 1994.
- 1614 Standard format and procedures for ship reporting, including dangerous goods, harmful substances and/or marine pollutants.
- 1643 MARPOL 1, Notice to shipowners, Masters, Certifying Authorities and Surveyors.
- 1678 (M+F) The Special Waste Regulations, 1996.
- 1703 (M) The Merchant Shipping (Dangerous or Noxious Liquid Substances) Regulations, 1996.
- 1709 (M+F) Port Waste Management Plans.
- 1720 (M+F) Merchant Shipping (Prevention of Pollution by Garbage) Regulations, 1998
- 1741 (M) Reporting requirements for ships carrying dangerous or polluting goods.
- MGN 33 (M+F) Sewage systems on ships associated hazards, installation and maintenance.
- MGN 37 (M) The Merchant Shipping (dangerous goods and marine pollutants) Regulations, 1997.
- MGN 79 (M+F) Safety Equipment and Pollution Prevention Equipment Carried in Excess of Statutory Requirements.
- MGN 81 (M+F) Guidelines for the Control and Management of Ships Ballast Water to minimize the Transfer of Harmful Aquatic Organisms and Pathogens.
- MGN 82 (M+F) Inadequacy of Reception Facilities for Oil Residues and Mixtures Noxious Liquid Substances and Garbage.
- MGN 110 (M+F) Shipboard Oil Pollution Emergency Plans.
- MGN 142 (M+F) MARPOL 73/78 - ANNEX VI: Control of Emission of Nitrogen Oxides (Nox) From marine diesel engines.
- MGN 143 (M+F) MARPOL 73/78 - ANNEX VI: Standards/Certificates Related to shipboard Incineration of Waste.

SHIPHANDLING

MGN 145 (M)	Merchant Shipping (Dangerous Goods and Marine Pollutants) Regulations, S.I. 1997/2367.
MIN 42	Merchant Shipping (Prevention of Oil Pollution) Regulations, 1996. Arrangements for Survey and Certification, S.I. 1996/2154.
MIN 57	Merchant Shipping (Dangerous or Noxious Liquid Substances in Bulk) Regulations, S.I. 1996/3010.

OSTMETC SHARED FILES
"NOT FOR SALE"

APPENDIX TO CHAPTER 10

*Contracting Governments to the 1954 Convention,
as amended up to 1969*

The Democratic and Popular Republic of Algeria
The Argentine Republic
The Commonwealth of Australia
The Republic of Austria
The Commonwealth of the Bahamas
The Kingdom of Belgium
The People's Republic of Bulgaria
Canada
The Republic of Chile
The Republic of Cyprus
The Kingdom of Denmark
The Dominican Republic
The Arab Republic of Egypt
Fiji
The Republic of Finland
The French Republic
The German Democratic Republic
The Federal Republic of Germany
The Republic of Ghana
The Revolutionary People's Republic of Guinea
The Hellenic Republic
The Republic of Iceland
The Republic of India
The Republic of Ireland
The State of Israel
The Italian Republic
The Republic of the Ivory Coast
Japan
The Hashemite Kingdom of Jordan
The Republic of Kenya
The Republic of Korea
The State of Kuwait
The Lebanese Republic
The Republic of Liberia
The Socialist People's Libyan Arab Jamahiriya
The Democratic Republic of Madagascar
The Republic of Malta
The United Mexican States
The Principality of Monaco
The Kingdom of Morocco
The Kingdom of the Netherlands
New Zealand
The Federal Republic of Nigeria
The Kingdom of Norway
The Republic of Panama
The Independent State of Papua New Guinea
The Republic of the Philippines
The Polish People's Republic
The Portuguese Republic

OSTMETC SHARED FILES
"NOT FOR SALE"

SHIPHANDLING

The State of Qatar
The Kingdom of Saudi Arabia
The Republic of Senegal
Spain
The Republic of Surinam
The Kingdom of Sweden
The Swiss Confederation
The Syrian Arab Republic
The Tunisian Republic
The Union of Soviet Socialist Republics
The United Kingdom of Great Britain and Northern Ireland
The United States of America
The Oriental Republic of Uruguay
The Republic of Venezuela
The Yemen Arab Republic
The People's Democratic Republic of Yemen
The Socialist Federal Republic of Yugoslavia

Territories to which the 1954 Convention has been extended

Bermuda
Netherlands Antilles
Puerto Rico, Guam, US Virgin Islands, American Samoa, the Trust Territory of the Pacific Islands, the Midway Islands, Wake Island and Johnston Island

SHIPHANDLING

APPENDIX

SEAMAN'S SELF-EXAMINER



The headings indicate the examinations to which the following questions and answers are directed.

OFFICER OF WATCH CERTIFICATES (ORAL)

1. **Qu.** What are the three main adjustable errors applicable to the marine sextant?
Ans. 1. Adjustment for the error of perpendicularity.
2. Adjustment for side error.
3. Adjustment for index error (parallax).
2. **Qu.** What types of anchor would you consider to be of high holding power?
Ans. A.C. 14, Flipper Delta or Bruce.
3. **Qu.** What is contained in the *Weekly Notices of Mariners*?
Ans. An index to all chart corrections effective in that issue, temporary and preliminary notices, corrections to charts, corrections to light lists, and corrections to radio signal lists, corrections to admiralty sailing directions and navigational warnings.
4. **Qu.** If a liquid magnetic compass was said to be 'dead beat', what would you understand from this statement?
Ans. That the card was steady and did not oscillate easily with the ship's movement.
5. **Qu.** How would you remove an air bubble from a liquid magnetic compass?
Ans. Turn the compass bowl on its side, in the gimbal arrangement, the expansion chamber uppermost.
Unscrew the expansion chamber and top up the fluid with a clear alcohol spirit, e.g. gin. (Surgical spirit should not be used as it will only cloud the mixture.)
6. **Qu.** How many rocket line throwing apparatus would you expect a Class VII vessel to carry on board? What is the distance

- that each line throwing apparatus must be able to cast the line?
- Ans.** Four self-contained line throwing units. Each unit contains 275 m of line, but the specification must be such that each line throwing apparatus is capable of 230 m.
7. **Qu.** List your actions as officer of the watch when the vessel is secured alongside in harbour and a fire is discovered in Number 2 hold of a general cargo vessel?
- Ans.**
1. Raise the alarm (stop cargo operations, if working).
 2. Call the local fire brigade.
 3. Ensure that no persons are in the hold and batten down as soon as practical, closing off ventilation.
 4. Remove all non-essential personnel from the vessel.
 5. Start boundary cooling.
 6. Assess the situation, by internal inspection if appropriate.
 7. Advise the harbour authority as soon as possible.
 8. Assemble damage control and fire parties and attempt to restrict and control the fire.
 9. Have ship's personnel at the head of the gangway to act as guides for the local brigade.
 10. Obtain fire documents, plans etc. (fire envelope).
 11. Check fire wires, forward and aft.
 12. Stand by main engines.
8. **Qu.** When joining a new ship as a watch officer, what would you check with regard to ship's radar?
- Ans.** Operate the performance monitor to ensure that the radar set was functioning correctly. Check blind sector arcs, and familiarise yourself with all the controls of the set, before getting under way.
9. **Qu.** How would you stow 2000 drums of corrosive as deck cargo, all in one batch or in small groups at various places on the deck? Explain your answer.
- Ans.** Stow the drums of corrosive in smaller separate groups. This type of stowage will allow easy inspection during the voyage. Leaking drums will be accessible and can be disposed of.
10. **Qu.** Explain how you would rig up a slip wire to a mooring buoy in the forepart of your vessel.
- Ans.**
1. Flake the slip wire on deck to allow free running.
 2. Seize the eye of the wire to allow it to pass through the ring of the mooring buoy.
 3. Secure the forepart by head lines to steady the bow, before running the slip wire.
 4. Lower the slip and a messenger down to a mooring boat.
 5. Check that the men in the mooring boat have lifejackets, especially the man who intends to 'jump the buoy'.
 6. Pass the seized eye of the slip through the ring of the buoy.

7. Secure the messenger.
8. Allow the mooring boat to clear the buoy area, then heave away on the messenger to recover the ship.
9. Turn up the slip by figure eight on the bitts.
(Don't place the eyes of the wire over the bitts)
- When running out, allow some slack on the slip and the messenger, to be coiled in the stern of the mooring boat.
11. **Qu.** When you are beaching a lifeboat, what signal would the coastguards send in the morse code to indicate they do not want you to make a landing?
- Ans.** 'S'.
12. **Qu.** What would you, as OOW, tell lookouts to watch for when searching for a life raft at night by means of searchlights?
- Ans.** (a) The white light on the outer canopy.
(b) The pyrotechnics – six hand-held flares, four rocket parachute flares.
(c) A flashing torch.
(d) The retro-reflective tape on the outside of the canopy.
(e) The orange hue given off by the canopy colour.
13. **Qu.** What is stowage factor?
- Ans.** The average cubic space occupied by 1 tonne of cargo.
14. **Qu.** How would you find the size of your anchor cable and what instrument would you use?
- Ans.** Measure the diameter of the bar from which the link is made by means of callipers.
15. **Qu.** If you are forced to cross over fishing nets, explain how you would do this and what precautions you could take?
- Ans.** Cross over the nets at right-angles to spend as little time over them as possible. Alter the ship's course to pass between fishing buoys, if seen. Call the Master in plenty of time and stop the ship's propeller as the vessel passes over the nets.
16. **Qu.** What are the characteristics of the stern light of a power-driven vessel which is more than 50 m in length?
- Ans.** Range not less than 3 miles, arc of visibility 135° (12 points of the compass), and positioned at or near the stern.
17. **Qu.** What is the day signal for a vessel proceeding under sail and power?
- Ans.** A black cone, apex, down, exhibited in a place where it can best be seen.
18. **Qu.** What is the minimum recommended safe passing distance off an oil rig. Indicate where you would obtain this information?
- Ans.** 500 m. *Annual Summary of Notices to Mariners or in the Mariners Handbook.*
19. **Qu.** To which vessels do the 'collision avoidance rules' apply?
- Ans.** All vessels upon the high seas and in all waters connected therewith navigable by seagoing vessels.
20. **Qu.** Give the day signal, together with its size, for a vessel constrained by its draught?

- Ans.** A black cylinder having a diameter of not less than 0.6 m and a height twice its diameter.
21. **Qu.** What are the recommended safe passing distances off a mine clearance vessel engaged on mine clearance duties?
- Ans.** 1000 m. Mariners are advised to give as wide a berth as possible.
22. **Qu.** Under Rule 35 (g) a vessel aground may sound an appropriate whistle signal, in addition to her normal fog signal. What would you suggest as an appropriate whistle signal in this context?
- Ans.** International Code signals 'U' or 'L' to mean: 'U' 'You are running into danger', or 'L' 'You should stop your vessel instantly'.
23. **Qu.** You are aboard a power-driven vessel and approaching a pilot station. You do not require a pilot. What orders and instructions would you give as officer of the watch?
- Ans.** Instruct lookouts to be watchful for small pilot cutters in the area. Reduce your own vessel's speed to avoid 'swamping' any small boats in the vicinity. Make an entry in the log book recording the reduction of speed as the vessel passes through the area. Advise the pilot station by VHF that you are passing through and do not require a pilot.
24. **Qu.** A vessel at anchor is engaged in underwater operations. What would be its fog signal?
- Ans.** One prolonged blast followed by two short blasts on the whistle, at intervals of not more than two minutes.
25. **Qu.** What does the two-flag hoist 'YG' signify?
- Ans.** 'You appear not to be complying with the traffic separation scheme'.

CLASS 2 CERTIFICATES OF COMPETENCY (ORAL)

1. **Qu.** As chief officer of a vessel, what action would you take on receiving orders to proceed to 'drydock' when the vessel still has 500 tonnes of Scotch whisky aboard, stowed in Number 1 lower hold?
- Ans.** Make immediate arrangements for a lock-up stow of the cargo. Ensure that the drydock authorities are informed of the cargo in order for additional shores or blocks to be positioned to compensate for stress. Order a special nightwatchman for the period of drydock. Maintain regular fire patrols within the hold area, to guard against pilferage and any other damage to the cargo.
2. **Qu.** What is the period of validity of the following certificates: De-rat certificate, ship construction certificate, lifesaving appliance/equipment certificate (cargo ships), and cargo safety radio telegraphy certificate?
- Ans.** De-rat, 6 months.

Safety construction, not more than 5 years.

Safety equipment, not more than 2 years.

Safety radio, 1 year.

3. **Qu.** A fire is discovered in the engine room of a vessel at sea. After attempting to fight the fire by conventional means, it is decided to inject 'bulk CO₂'. Describe your actions as officer in charge in order to activate the carbon dioxide flood system.

- Ans.**
1. Order the fuel and boilers to be closed down within the engine room. (Close off all ventilation if not already done.)
 2. Evacuate the engine room of all personnel.
 3. Carry out a roll call or head count of all personnel.
 4. Check the amount of CO₂ gas to be injected, by comparison with the planned injection information. (This plan is usually displayed on the bulkhead of CO₂ room.)
 5. Open the firing cabinet door, causing the alarm to activate.
 6. Operate the firing handle/mechanism to fire the pilot bottles.

Some flood systems may require a valve to be activated to allow the gas access into the space.

4. **Qu.** After a collision at sea, the order to abandon ship is given. What would you check crew and passengers for, once they are mustered at their respective boat stations?

- Ans.** All duty officers in charge of boats and all cox'ns would be instructed to ensure that all persons are adequately clothed and that lifejackets are properly secured. A complete muster list must be taken for each boat or craft.

5. **Qu.** As officer of the watch on a vessel at anchor, you discover that another vessel is dragging its anchor and is in fact dragging down towards your own vessel. What sequence of actions would you expect to go through?

- Ans.**
1. Order main engines ready for immediate use.
 2. Order an anchor party to stand by forward.
 3. Sound five or more short and rapid blasts on the ship's whistle.
 4. Inform the Master of the situation immediately.
 5. Draw the attention of the vessel dragging her anchor by calling up on the VHF.
 6. Additionally, call attention to the situation by use of the Aldis Lamp.
 7. Stand by to (a) pay out more cable, (b) heave away on the cable and move the vessel forward, (c) go ahead on engines and steam over your own cable, and (d) provide the vessel with a sheer, by a hard over action of the rudder.

8. Have a man stand by the wheel.
 9. See that an entry of events is made in the log book.
 10. Make full use of international code flags during the hours of daylight.
6. **Qu.** When working two 5-tonne derricks in 'union' purchase' rig, what particular safety aspects would you warn a junior officer to take account?
- Ans.** All winch drivers should be seen to be competent and responsive to the hatch controller. Derricks should be plumbed correctly and all guys and preventers should be rigged in a proper manner. All shackles employed on the rig are to be moused and within the correct safe working loads. The SWL of the union rig (1.6 tonnes) should not be exceeded. The cargo runner should be seen to be in good condition and the angle between the runners should not exceed the safe working angle of 90° for normal working.
7. **Qu.** When officer of the watch, you see a man fall overboard from the fo'c'sle head area. List what actions you would expect to take.
- Ans.**
1. Helm alteration to keep the propeller clear of the man in the water, preparatory to starting Williamson turn.
 2. Main engines on standby, for immediate manoeuvre.
 3. Release the bridge wing lifebelt/smoke float.
 4. Sound general alarm/emergency boat stations.
 5. Advise the Master of the situation.
 6. Post lookouts.
 7. Hoist 'O' flag during daylight hours.
 8. Advise coast radio stations and other shipping in the area by VHF.
 9. Communications officer to stand by.
 10. Emergency boat to be made ready to launch.
 11. Hospital prepared to treat for shock and hypothermia.
 12. Continue manoeuvre to effect recovery or commence sector search.
8. **Qu.** As chief officer of a vessel, how would you instruct the bosun to renew a damaged cargo runner quickly during cargo operations?
- Ans.** Turn off all the damaged runner from the winch barrel and secure a rope messenger to the Flemish eye of the runner. Draw all the cargo runner off the derrick, pulling the rope messenger behind from the direction of the cargo hook end. Detach the old runner once clear of the derrick and secure the Flemish eye of a new runner to the messenger. Pull back on the messenger, bringing the new runner down the length of the derrick. Reconnect the eye to the barrel of the winch and run on the desired amount. Resume the rig for working cargo.
9. **Qu.** Where would you normally keep certificates of wires, blocks, shackles, chains etc.?

- Ans.** Register of ships Lifting Appliances & Cargo Handling Gear.
10. **Qu.** When lifting a 9-tonne load with a 10-tonne SWL derrick, what additional factors would you take into consideration with regard to possible overloading of the rig?
- Ans.** The weight of slings, shackles and securing arrangements must be considered within the total load.
11. **Qu.** Explain the arrangement of a Mediterranean moor and state its principal advantages?
- Ans.** The vessel is moored 'stern to the quay', being secured by both anchors forward in an open moor situation. The aft end of the vessel is secured by two stern lines and two crossed springs from each quarter. The advantage of this moor is that more than one vessel can secure to limited quay space. Also, when discharging/loading cargo from barges, both sides of the vessel can be worked at the same time.
12. **Qu.** When about to bring the vessel to a single anchor, what factors would you check and investigate before letting go the anchor?
- Ans.** Careful investigation of the charted area to obtain depth of water, type of holding ground and tidal effects, and the options for good, well spaced anchor bearing points. Obtain a current and long-range weather forecast and consider a sheltered anchorage position, preferably in the lee of the land away from prevailing winds. The anchorage should not to be so close to the land as to pose a threat of a lee shore in the event of wind change. Prepare an anchor approach plan beforehand.
13. **Qu.** How would a new danger be marked in accordance with the IALA system of buoyage?
- Ans.** A new danger would be marked by one or more cardinal or lateral marks in accordance with the rules of the system. If the danger is an especially grave one, then at least one of the marks will be duplicated as soon as is practical by an identical mark. The duplicate mark will remain in position until the danger has been sufficiently publicised. The duplicate mark may carry a Racon, coded morse 'D' (- · ·) showing a signal length of 1 nautical mile on a radar display. The buoys would have quick or very quick flashing lights.
14. **Qu.** Describe the preferred channel mark to starboard as employed by the IALA system of maritime buoyage (System 'A').
- Ans.** Red can, pillar or spar buoy having a single broad green band round its centre. The spar or pillar buoys may carry a red can topmark. The light shown would be the composite group flash (2 + 1) red.
15. **Qu.** For what areas of navigation would you expect to find and employ a chart in gnomonic projection?
- Ans.** Used for polar navigation in the high latitudes, and when

- laying off great circle sailings before starting a voyage. It is not unusual to find the plan of a port or harbour printed on a mercator chart set in the gnomonic projection.
16. **Qu.** A vessel seen ahead is apparently engaged in fishing. In addition to its normal fishing lights, it shows two flashing yellow lights in a vertical line. What do these yellow lights mean to you?
- Ans.** That the fishing vessel is engaged in purse seine net fishing.
17. **Qu.** What is a safe speed?
- Ans.** A safe speed must be that at which a vessel can take proper and effective action to avoid collision and stop within a distance appropriate to the prevailing circumstances and conditions.
18. **Qu.** A power-driven vessel stops on the water at night. What navigation lights will she switch off?
- Ans.** None. The vessel is showing no special signals and is doing nothing untoward. Should there be the possibility of a collision, she could always restart her engines and commence making way.
19. **Qu.** What fog signal would a pilot vessel make when engaged on pilotage duty?
- Ans.** When under way and making way, one prolonged blast at intervals of not more than 2 minutes. When under way but stopped, two prolonged blasts in succession at intervals of not more than 2 minutes. When at anchor, rapid ringing of the bell for about 5 seconds at intervals of not more than 1 minute. (If she was over 100 m in length, then this would be accompanied by the gong signal.) In addition, she may sound an identity signal of four short blasts.
20. **Qu.** What are the obligations of the 'stand on' vessel as directed by the rules?
- Ans.** To stand on and maintain her course and speed. When from any cause the stand on vessel finds herself so close that collision cannot be avoided by the action of the give-way vessel alone, she also shall take such action as will best aid to avoid collision.
21. **Qu.** What additional day signals are fishing vessels allowed to exhibit to indicate the following:
- Hauling nets.
 - Shooting nets.
 - Nets have become fast on an obstruction.
- Ans.** (a) 'G' flag (for grabbing nets)
 (b) 'Z' flag (for zooming nets)
 (c) 'P' flag (for pinned nets)
22. **Qu.** A vessel exhibits normal steaming lights together with a flashing 'amber' light. What type of vessel could this be?
- Ans.** A submarine or a hovercraft.
23. **Qu.** If your vessel was to be taken under tow, what lights would you show at night?

- Ans.** Sidelights and stern light.
24. **Qu.** When on passage up a river a small craft is showing a rigid replica of the 'A' international code flag. What does this signal mean and what action would you take as OOW?
- Ans.** Code flag 'A' signifies, 'I have a diver down, keep well clear at slow speed'. As OOW, you should give a wide berth to the craft, and reduce your own vessel's speed on approaching and passing the area.
25. **Qu.** You are navigating with extreme caution in thick fog aboard a power-driven vessel. An order is given to 'stop engines'. At what time will you change your vessel's fog signal from one prolonged blast to two prolonged blasts, at intervals of not more than 2 minutes?
- Ans.** When the vessel stops making way through the water.

CERTIFICATE OF COMPETENCY FOR MASTER MARINER, CLASS 1

1. **Qu.** You are called to the bridge in your capacity as Master of the vessel. The junior officer of the watch reports that red parachute flares have been sighted four points off the port bow. What action will you take?
- Ans.** Assess the situation by questioning other lookouts to corroborate the officer's sighting. Check with the officer the vessel's own position and estimate the position of the flares, putting both estimated positions on the chart. Report the sighting of flares to the nearest radio station and obtain reports from that station on craft reported mission. Double lookouts and alter course to investigate the sighting on the basis that red parachute flares are a recognised distress signal. Note the time of alteration of the vessel's course, and enter the alteration into the log book. The deviation is logged for the purpose of the charter party.
2. **Qu.** The officer of the watch reports that he has just sighted a submarine sunk buoy passing down the port side. What action will you take as Master of the vessel?
- Ans.** Assume command of the bridge and order 'stand by engines'. Start to circle the buoy and obtain the position of own vessel. Establish by a succession of bearings and distance whether the buoy is adrift or attached to a submarine. Investigate the charted depth of water and report the findings to the coastal radio station for relay to Ministry of Defence, Admiralty (in the case of Royal Navy submarines).
- Continue to circle the area, keeping the main engines turning at slow speed. Switch on echo-sounder and have a man hammer at the turn of the bilge. This should indicate to the submarine that the buoy has been sighted and a vessel is at the surface.
- Clear away the emergency boat in case persons try to

escape from the submerged craft. (In less than 15 fathoms of water this escape practice is a distinct possibility.)

Provide the shore authorities with an updated report as soon as practical. Should daylight be closing, rig and check searchlights and delegate operators for these, in addition to lookout personnel.

3. **Qu.** On passage from the United Kingdom to Canada your vessel encounters dangerous ice concentrations. What are your obligatory duties as Master of the vessel?

Ans. To proceed at a moderate speed at night or to alter course to pass well clear of the danger zone. Make out an ice report to be passed via the coast radio station to the ice patrol. The report should contain the following information: type of ice, position of the ice, GMT and date of observation.

4. **Qu.** When recovering your anchor, you realise that you have inadvertently fouled a submarine cable. What action would you take?

Ans. Make every effort to clear the anchor from the fouled cable without causing damage to the cable. Should this course of action fail, slip the anchor cable and abandon the anchor. If forced to slip, buoy the end of the cable to facilitate recovery at a later time. Advise the authorities of the incident and position of the foul. Enter a statement in the log book, advise the owners of the vessel, and take steps to obtain a second (spare) anchor and cable to return the vessel to a seaworthy state.

5. **Qu.** If your vessel is in collision with another vessel, what are your statutory duties as Master?

Ans. It is the duty of every Master or person in charge of any vessel in collision to:

Render to the other vessel, her Master, crew and passengers (if any) such assistance as may be practicable or necessary to save them from any danger caused by the collision, and to stay by the other vessel until it has been ascertained that she has no need of further assistance. Furthermore the Master must give the Master or person in charge of the other vessel the name of his own vessel, the port to which she belongs, and the ports, from which she is sailing and to which she is bound.

6. **Qu.** When in command of a twin-screw vessel you suffer a complete breakdown of the steering gear, what action would you expect to take?

Ans. Depending on the position of the vessel it may be prudent to stop and take all way off the vessel, or even come to an emergency anchorage if the depth of water allows. Failing either of these options, adjustment of engine revolutions will permit reasonable steering for a limited time, depending on available sea room. Whatever option is taken, the vessel

Legal addition: The Master or Officer in charge must also report a collision to the Marine Accident Investigation Branch (MAIB) and cause an entry to be made into the official log book.

should be considered not under command and the respective day signal and/or lights displayed. Start emergency repairs as soon as possible.

7. **Qu.** On assuming command of a new passenger/ferry type vessel, explain how you would instruct your officers to disembark 600 passengers in an orderly manner, so as to avoid panic?

Ans. Officers would be informed of the 'muster points' for all passengers, and that these assembly points would be the public rooms, i.e. lounges, dining area etc. Passengers should then be despatched towards the embarkation deck to be loaded into survival craft, from the assembly points. Small groups of 20 or 25 should leave the assembly points to avoid panic in the lifeboat or raft areas. This number of persons can also be reasonably controlled, and a roll call can be more accurately obtained at the point of disembarkation. Most survival craft will accommodate 20 persons or multiples of 20, e.g. 4 × 15 man rafts, large lifeboats 60 person capacity, davit-launched rafts 20 and 25 man sizes.

8. **Qu.** When aboard a vessel at sea about to receive a transfer from a helicopter, state any instructions you would issue to ship's officers to ensure a safe operation?

Ans. Brief all operational personnel before the operation takes place, paying particular attention to the following points:

1. Ensure that all rigging and obstructions about the helicopter landing/transfer area are cleared away.
2. Secure or stow away any loose items which may become caught with the down draught from helicopter rotor blades.
3. Check communications with the deck controlling officer and check liaison between the bridge and helicopter.
4. Muster damage control/fire parties close enough to the area of operations as to be available in an emergency.
5. See static hook handler is properly equipped.
6. Display a windsock or smoke signal.
7. Observe helicopter operations procedure.
8. If operating at night, provide adequate lighting without blinding the helicopter pilot.

9. **Qu.** Describe the AMVER organisation?

Ans. The name AMVER stands for the Automated Mutual Assistance Vessel Rescue System. It is operated by the United States Coastguard to provide aid in the co-ordination of a search and rescue operation, or other similar emergency. Vessels are encouraged to participate in position reporting in order to offer or receive aid when required. Efficient communications and the combined capabilities of many vessels can provide speedy assistance in time of need.

10. **Qu.** After a lengthy structural refit in drydock, during which

considerable alterations have been made to the vessel, what, if any, actions would you insist on with regard to the ship's compasses?

Ans. Arrangements should be made for the vessel to be 'swung' after leaving the drydock and in clear water away from any magnetic anomaly, before the next voyage begins. It would be prudent, anyway, to have the compasses taken ashore to a nautical optician during the refit.

11. **Qu.** A small fishing boat with five men on board is seen to be in distress. You are informed as Master that this small vessel is sinking and you are therefore obliged to make a rescue attempt. The prevailing weather conditions are very rough sea, wind Force 8. What options do you have in attempting to rescue the fishermen?

Ans. With the weather conditions being so bad, it would probably be impracticable to lower one of the ship's lifeboats without considerable risk to the boat's crew. The remaining options are the following:

- (a) Employ one of the life rafts belonging to the fishing vessel as a means of transporting the survivors from one vessel to the other, contact being made by rocket lines.
- (b) Employ one of the rescue vessel's life rafts in a similar manner as already stated.
- (c) Go alongside the fishing vessel if circumstances permit. This option would depend on the difference between freeboards of the two vessels. In addition, the constructional features of the rescuing vessel might make the approach to the sinking craft so difficult, that a bow or stern rescue would be more appropriate, especially, say in the case of a RoRo, vessel. Scrambling nets overside may be useful.

12. **Qu.** You are 'hove to' head into the sea. Discuss how you would turn the vessel in this heavy weather, in an attempt to run before it.

Ans. In general a ship's turning circle is smaller when carried out at slow speed. The turn, therefore, should not be made at full speed, but at a slow speed, with 'bursts' on the ship's main engines to cause the propeller to bite and produce greater rudder effect. The turn should be executed in such a manner that the vessel is beam on to the weather only during relatively calm periods between waves. Waves tend to travel with variable frequency, so that such calm periods do occur. It is by careful observation of the sea state that these calm periods can be estimated and the turn successfully completed.

13. **Qu.** CO₂ gas has been injected from a bottle bank to extinguish an engine room fire. What are your actions as Master of the vessel, if you think the fire is out?

Ans. Providing that there are no other adverse conditions, e.g. 'bad weather', to complicate the situation, it would be advisable to wait before carrying out any inspection. This waiting period could be usefully employed by maintaining 'boundary cooling' and observing the temperatures of the steel work at various levels around the engine room casing. Once a distinct fall has been observed in temperatures, an internal inspection and assessment may be ordered.

Breathing apparatus should be worn by two persons, one acting as back-up to the inspecting officer, who should be a responsible engineer who would know the engine room layout and be able to make a comprehensive report (probably the second engineer). The inspection personnel should be equipped with spray fire fighting equipment.

Once the inspection report has been made, a further delay may prove a prudent move in order to allow hot metal to cool down further. At no time should oxygen have access to the engine room area. An additional assessment should now be made by internal inspection, probably by the chief engineer. This would not only provide a more experienced assessment but a worthwhile second opinion.

Should both opinions agree that the fire is out, a further delay would be considered before a damage control party entered the engine room for cooling down work. When all metal components have cooled, ventilation may be started.

14. **Qu.** After a collision with another vessel, in which your own ship suffers considerable damage, you decide to beach the vessel to avoid sinking. Discuss your actions before and on taking the beach.

Ans. Once the decision to beach has been made, the aim is to land in a manner to reduce further damage, with the view to refloating at a later stage. A gentle sloping, sandy beach would be the ideal place.

The approach would normally be made in the 'end on' position, if at all possible. This would tend to restrict additional damage to the forefoot and the bottom plates, while favouring the bilge areas. The damage might be contained by the collision bulkhead and the tank tops of the double bottom.

If circumstances permit, one or both anchors should be let go and paid out as the approach to the beach is made. Care should be taken that the anchors are let go clear of the position at which the vessel intends to come to rest. A real danger of letting go anchors when in the process of beaching is that the vessel may come to rest sitting on top of them, causing severe damage to the double bottom structure. The advantage of having anchors out off the stern quarter(s) is that considerable weight can be put on to the cables when attempting to heave the vessel back afloat.

There is advantage in approaching the beach at a slight angle. The port anchor is let go and the ship turned to port to take the beach end on. This will keep the anchor clear of the bottom and help keep the vessel straight when coming off with engines going astern.

Before taking the beach, if time permits, the ship's ballast tanks should be filled. This will not only assist the vessel when the time comes to refloat, by allowing the trim of the craft to be changed, but also it will add strength to the fore end at the time of taking the ground. Moreover, with full ballast, should the weather turn for the worst, then the additional weight of ballast would help prevent the vessel from bumping and working herself further up the beach and damaging the bottom plates.

Once the vessel has landed, it is necessary to make a complete sound round all the vessel's tanks, together with a complete sound round the vessel's hull to find out the depth of water, specifically around the ship's propeller. The engines should be stopped immediately on taking the ground. Should this not happen, the soundings may show build-up of a mud or sand bank directly astern, which may hamper the operation of refloating.

Make a full assessment of damage to the ship and instigate emergency repairs as soon as possible. Note any casualties and return a comprehensive damage report to owners and relevant authorities. See that an entry is made in the ship's log book as soon as practical after the event.

Check the vessel's position, and seek information on the next high tides and on the state of the tide when striking the beach. Examine leaking compartments, plug or patch as required and pump dry any flooded areas. Obtain updated weather reports as soon as possible after the event.

15. **Qu.** You are aboard an ice-strengthened vessel and navigating in 'close pack ice'. Discuss in general terms your actions as Master and your navigational progress.

Ans. It is generally accepted that any vessel navigating in ice should endeavour to keep moving, no matter how slowly. Once a vessel becomes trapped in ice, then she goes wherever the ice moves, not where the Master wishes.

Progress will depend on successfully following leads in the pack ice field. The vessel's speed should be considerably reduced for any form of ice navigation, especially when in close pack ice. Should the vessel be stopped by the sheer weight of ice ahead, main engines should be put astern to allow her limited freedom of movement. The action of going astern may also cause ice movement in the way of cracks and new leads. When re-entering ice after a stern movement, the vessel should proceed slowly then increase speed in order to maintain headway.

Double lookouts should be employed throughout ice navigation, with searchlights being used during the hours of darkness. The position of the vessel should be kept under regular observation and good communications with shore radio stations maintained.

Probably the most vulnerable parts of any vessel navigating in heavy ice concentrations are the propellers, especially when the vessel is moving astern, and great care should then be observed. At no time should the vessel attempt to break through glacial ice. This type of ice formation is usually very large and extremely solid and should be given a wide berth.

Should the vessel become 'stuck' in ice, then limited alternatives are open: (a) go astern, (b) put rudder midships and leave engines running ahead to clear ice floes astern, or (c) transfer ballast and change trim to bring about the vessel's release. Masters should avoid using anchors, if at all possible. Should the ice be moving, there would be a distinct possibility of breaking the anchor cable for the cable and the ship's bow might act to trap large moving ice floes.

It is dangerous to follow close inshore leads, especially when an onshore wind is blowing. Ice convoys and the assistance of ice-breaker patrol ships are the obvious and safest guarantees of transit, but these specialised ice strengthened vessels may not always be present when they are needed.

16. **Qu.** When siting the position of the ship's whistle in accordance with Annex III of the rules, state why it should be positioned as high as practicable, and if more than one whistle is fitted, state when they would not be sounded simultaneously.

Ans. Whistles should be positioned as high as practicable so as to transmit their signal as clearly as possible without interference from obstructions. If more than one whistle is fitted and the distance between them is more than 100 m, they should not be sounded simultaneously.

17. **Qu.** You are navigating in a narrow channel when a vessel astern sounds two prolonged blasts, followed by one short blast on the whistle. What do you understand from this signal and what action would you expect to make on your own vessel if you are in agreement with the purpose behind the signal?

Ans. The whistle signal indicates 'I intend to overtake you on your starboard side' (Rule 34(c)). If the vessel to be overtaken is in full agreement with the proposed action, a return signal of one prolonged, one short, one prolonged and one short blast, should be made by the vessel to be overtaken, which should then take the necessary action to allow overtaking.

SHIPHANDLING

18. **Qu.** When navigating in a traffic separation scheme, a junior watch officer calls you to the bridge in your capacity as Master of the vessel. A crossing situation with another vessel is apparent. The crossing vessel is positioned 4 points off the port bow at an approximate range of 3.5 miles. State what would be your probable action in the circumstances and justify your answer.

Ans. I would assess the situation with regard to such navigation hazards as other traffic or shallow water, and check the systematic plot on the radar against the visual aspect of the crossing vessel. Observing the collision regulations in respect of the fact that mine was the stand on vessel, I would maintain my course and speed.

Should the situation continue to develop, I would expect to take the following action: sound five or more short and rapid blasts on the ship's whistle to indicate doubt as to the intentions of the crossing vessel. If no corrective action was immediately taken by that vessel in response to this signal, then I would instigate the following actions so as to avoid collision: sound one short blast on my ship's whistle and make a broad alteration of course to starboard, or take all way off my own vessel immediately. In no way would the presence of the separation scheme alter my action.

19. **Qu.** On a vessel at anchor in restricted visibility, what additional sound signal may be made before or after the normal fog signal in order to give warning of the vessel's position? May this signal be used in clear visibility? If it is not to be used, explain why not.

Ans. A vessel at anchor may in addition to the normal fog signal sound three blasts in succession, namely one short, one prolonged, and one short blast, in order to indicate her position. This signal is prescribed by the rules under the heading for sound signals in restricted visibility only. Therefore, it would not be sounded in clear visibility.

20. **Qu.** When navigating in a narrow channel, with shallows and exposed banks either side, a large dry cargo vessel is confronted with a small speedboat (less than 20 m in length) and a person on water skis. Directly in front of the vessel, the person loses his balance and falls from the skis. The cargo vessel is approximately $\frac{1}{4}$ mile from the man in the water. What action would you take as Master of the cargo vessel? By what authority are you taking this action?

Ans. As Master of the vessel, I would order main engines stopped and try to reduce way, possibly by going full astern. If there was room to manoeuvre inside the channel around the man in the water, then I would do so. Should this not be possible, I would order double full astern (crash full astern). Depending on the circumstances, I would try not to ground

the vessel. Regulation 9(b) – A vessel of less than 20 m in length shall not impede the passage of a vessel which can safely navigate only within a narrow channel or fairway.

21. **Qu.** Your vessel is approaching a vessel displaying lights which indicate she is engaged in fishing, when a searchlight is suddenly switched on and directed towards a point approximately $\frac{1}{2}$ mile ahead of you. What would you understand from this action and what would you instruct the officer of the watch to do?

Ans. Under Rule 36 of the regulations, I would assume that the vessel engaged in fishing was trying to attract my attention by directing a searchlight in the direction of the danger. I would require a full assessment of the situation and would stop my own vessel, take all way off and order the OOW to obtain a current position on the chart. I would compare the position with other charted navigation hazards, if any, and take action to avoid the area. I would communicate with the fishing vessel by VHF or Aldis lamp to establish the type of danger, and take action in accordance with the information received from the fishing vessel.

22. **Qu.** When navigating in clear weather, you see that your course will cause you to enter a fogbank right ahead. You instruct the officer of the watch to switch on the radar, tune the set in, and start making a fog signal. On entering the fogbank at a reduced speed, the OOW reports that the radar is tuned in and operational and that there is a target vessel 2 miles dead ahead on the heading line marker, radar being in the ship's head up presentation. What would be your probable intended action? Justify this action.

Ans. I would stop my vessel and take all way off, to avoid collision with the target vessel. Under the regulations, Rule 8, stopping and taking all way off would give me more time to carry out a systematic plot of the target and to make a full assessment of the situation. I would not take any immediate action other than that stated. Under Rule 7(c), assumptions should not be made on scanty information, especially scanty radar information.

23. **Qu.** When navigating in a narrow channel and rounding a 'blind' bend, you hear a sound signal of one prolonged blast, followed by two short blasts, at intervals of not more than two minutes. What action would you take aboard your own vessel?

Ans. Order an immediate reduction of the ship's speed and prepare to enter poor visibility. The sound signal around the bend is a fog signal of a hampered vessel. I would navigate with extreme caution until all risk of collision is over.

24. **Qu.** You are navigating in thick fog, when a target vessel is plotted on radar. You are Master of the vessel and in command

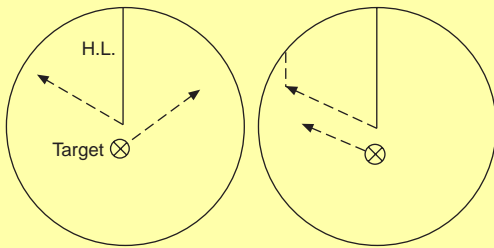

PPI Display 1.
Recommended action, on the assumption that the target will alter to starboard.

PPI Display 2.
Action if the target takes the alternative action of altering course to port.

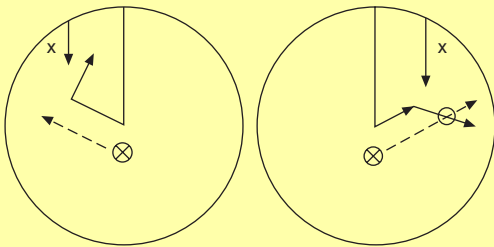

PPI Display 3.
By an alteration to port for the original target, you are able to alter to starboard for vessel 'X' and remain within the correct procedure of the regulations.

PPI Display 4.
If you had made an alteration to starboard, then by not being allowed to alter course to port for vessel 'X' an alteration to starboard would have resulted in another close quarters situation with the original target vessel.

of the bridge. The target vessel is reported by the OOW as being 4 miles dead astern, and its range is closing. Explain your probable action and justify this action.

Ans. In accordance with the instructions of Rule 19 of the regulations I would probably make a bold alteration of course to port. This action would be taken on the assumption that the target vessel would alter to starboard, if she is going to alter at all. The reasoning behind this is that to the other vessel I would appear forward of his beam.

However, Rule 19 recommends that the following should be avoided: 'an alteration of course to port for a vessel forward of the beam, other than for a vessel being overtaken'. If the situation is considered, it will be seen that the target vessel is overtaking, and therefore will have the option of an alteration of course to port or starboard (see opposite).

A bold alteration to port would provide definite information to the target vessel, if radar is being observed. This alteration would clearly take into account any shadow sectors being carried by the target vessel's radar position.

The reasoning behind the probable alterations of both your own vessel to port and the alteration of the target to starboard are illustrated opposite. Assume an additional target 'X' is on a reciprocal course (see opposite).

In all situations, any action taken will depend on full consideration of all the circumstances at the time. The answer provided in this question must be read with the weather and traffic conditions at the time in mind. A probable line of action is suggested, but there are alternatives.

25. **Qu.** What lights and fog signal would be exhibited by a pilot vessel on station when at anchor?

Ans. The vessel would show anchor lights, as for a vessel of her length, and white and red, all round lights, vertically displaced one over the other. The fog signal would be as for any other vessel of her length, but, in addition, she may sound an identity signal of four short blasts.

26. **Qu.** The employer must appoint a Safety officer, and it is the Master's duty as the employer's representative to ensure this is done, if the ship carries more than five (5) crew. Can the Safety Officer resign?

Ans. No. Unlike a safety representative who is elected by the crew. Safety representatives can be replaced by the crew electing another person to replace him.

27. **Qu.** Can the Safety Officer stop work being carried out on board?

Ans. Yes. The Safety Officer has the authority to stop any work being carried out which he considers may be unsafe or lead to unsafe practice.

28. **Qu.** What are the duties of the Safety Officer?

SHIPHANDLING

Ans. The Safety Officer would investigate any and all accidents on board the vessel. He would also obtain statements from witnesses to the accident and report his findings to the Safety Committee and complete the accident reports. He would also make recommendations on safe working practice and safety policy effecting the ship. He would also carry out regular Safety Inspections of all accessible areas of the vessel.

28. **Qu.** Where would you obtain details of the safety requirements regarding Safety Officers, Safety Committees, and safety policy affecting the ship?

Ans. Code of Safe Working Practice for Merchant Seamen.
Merchant Shipping Notices (MSNs)
Guidance Notes for Safety Officials (1982 S.I. 876)

30. **Qu.** What entries are required in the Official Log Book, regarding the ship's safety officials.

Ans. The Master must record all Safety appointments in the Official Log Book.

Q&A METC SHARED FILES
NOT FOR SALE

SHIPHANDLING

INDEX TO PART ONE



- 'A' Frame, 6
- Abandon ship, 222
- Abandon ship drill, 242
- Abeam, 1, 2
- Ahead, 2
- Alarm signals, 240
- Alternative tonnage mark, 23
- Amidships, 2
- Anchor and cable certificates, 29, 30
- Anchor and cable construction, 26–31
- Anchors and cable work, 25
- Anchor cable securement and fittings, 30–35
 - bitter end, 34, 41
 - bow stopper, 33, 37
 - cable holder, 38
 - cable joining shackles, 30–33, 40
 - 'D' Lugged, 32, 33
 - Kentor Lugless, 30, 31
 - cable locker, 33, 34
 - chain reliever, 38
 - compressor, 33, 35
 - devils claw, 33, 38
 - guillotine, 35
 - gypsy, 33, 36
 - hawse pipe, 33, 34
 - lashings, 37–41
 - scotsman, 38
 - snug, 35, 38
 - spurling pipe (naval pipe), 33, 35, 45
 - swivel, 33
 - windlass and capstans, 35–37
- Anchor moorings, 57, 58
 - Bruce, 57
 - improved mooring, 58
 - Trotman anchor, 58
- Anchor operations
 - approach plan, 38, 39
 - bell signals, 40
 - clearing foul hawse, 43, 50–52
 - deep water anchoring, 49
 - hanging off anchor, 54, 55
 - laying or carrying out anchors, 49, 50
 - marking cable, 40
 - recovery, 52, 53
 - re-securing spare anchor, 55–57
 - single anchor procedure, 39
- Anchor parts, 25–27
 - anchor crown 'D' shackle, 33
 - arms, 25, 26
 - crown, 25, 26
 - flukes, 25, 26
 - forelock, 25
 - gravity band, 25
 - head...of anchor, 26
 - pea or bill, 25
 - shank, 25, 26
 - stock, 25, 26
 - tripping palms
- Anchor terminology, 41–46
 - anchor 'a' cock a bill, 41
 - anchor aweigh, 41
 - anchor buoy, 41
 - anchor coming home, 42
 - anchor dragging, 42
 - anchor warp, 42
 - brought up, 42
 - cable clench, 42
 - cable length, 42
 - cat an anchor, 42
 - drop an anchor under foot, 42
 - foul anchor, 43
 - foul hawse, 43
 - cross, elbow, round turn, 43
 - ganger length, 54
 - grow, 43
 - gypsy, 43
 - hawse pipe, 34, 43
 - hove in sight, 43
 - joggle shackle, 44
 - kedging, 44
 - long stay, 44
 - ream out a shackle, 44
 - render cable, 44
 - scope, 44
 - shackle of cable, 44
 - sheer, 44
 - sheet anchor, 45
 - shorten cable, 45
 - short stay, 45
 - snub, 45
 - spurling pipe, 45
 - surge, 45
 - tiderode, 45
 - up and down, 45
 - veer cable, 45
 - walk back, 45
 - windlass brake, 34, 35
 - yaw, 46
- Anchor tests, 27, 29
 - bending test, 29
 - drop test, 27
 - percussion test, 27
 - proof loads, 28
- Anchor types, 25
 - Admiralty cast, 25
 - Admiralty pattern, 25
 - CQR, 26, 27
 - Danforth, 26, 27
 - Fishermans anchor, 25
 - Stockless anchor, 26
- Anchor watch, 46
 - dragging anchor, 46, 47
 - duty of OOW, 46, 47
 - transit bearings, 47
- Anchor work accessories, 38
 - cable jack, chain hook, drifts, 38

SHIPHANDLING

310

Index to part one

- Angle bar, 20
Answering pennant, 252, 253
Apron, 168
Awning screw, 89
- Bagged cargo, 155
Bailer, 174
Bale sling strop, 72, 156, 157
Bale space, 152
Ballast, 21
Ballast tank, 7
Band brake, 35
Barrel sling, single, double, 72
Barrel stowage, 155
Beaching, 198, 199
 lifeboat, 198
 liferaft, 227
Beam, 2, 4
Beam knees, 19
Beams, 19
Bends and hitches, 67–81
 blackwall hitch, 67
 bowline, 67, 68
 running bowline, 67, 68
 bowline on the bight, 67, 68
 catspaw, 69
 clove hitch, 69
 cow hitch, 69
 diamond carrick bend, 69
 double blackwall hitch, 67
 double carrick bend, 69
 double sheet bend, 71
 figure '8' knot, 69, 70
 fishermans bend, 70
 french bowline, 68
 marline spike hitch, 69, 70
 midshipmans hitch, 70
 reef knot, 70, 71
 rolling hitch, 70
 round turn and two half hitches, 70, 71
 sheep shank, 71
 sheet bend, 71
 single carrick bend, 68, 69
 timber hitch, 70, 71
Bilge pumping arrangement, 7
Bilge suction, 145, 146
Bilge turn of, 145
Binding, 98, 99
Bits, 35, 67
Blake slip, 91, 92
Block coefficient, 4, 5
Block internal fitments, 99
Block parts of, 98, 99
 arse, 98
 binding, 99
 bush, 99
 cheeks/plates, 99
 cross head, 99, 100
 crown head, 98
 distance piece, 99
 inspection plate, 98
 pin (bolt), 98, 99
 rope guards, 99
 sheave, 98, 99
 swallow, 98
 swivel hook/becket, 98–100
Block inspection, 98, 99
 lubrication, 98
 protection, 98
 order new, 98
Block maintenance, 99
Blocks and tackles, 100–105
Block types, 98
 chain blocks, 103–105
 external bound, 99
 gin, 99
 head block, 100
 heel block, 100
 internal bound, 99
 metal block, 99
 snatch block, 99
 wood block, 98
Blue ensign, 258, 259
Boat construction, 168
 carvel, 171
 clinker, 171
 double diagonal, 171, 172
 GRP (Glass reinforced plastic), 172
Parts of a lifeboat, 168
 Apron, 168
 bilge grabrail, 168, 172
 bottom boards, 172
 buoyancy chambers, 168, 172
 deadwood, 168
 filling piece, 168
 gangboard, 168
 garboard strake, 168
 gunwale, 168, 169, 172
 gunwale capping, 168
 hardwood chock, 168
 hog piece, 168
 keel, 168, 172
 keelson, 168
 lifting hooks, 168, 172
 mast thwart, 188
 painter shackle, 168
 rising, 168
 rubbing strake, 168, 172
 scarph, 168
 sheer strake, 168
 side bench, 168, 172
 sling plate, 168
 stem post, 168
 stem band, 168
 stern band, 168
 stern post, 168
 stretcher, 172
 tank cleading, 168, 172
 thwart, 168, 172
 thwart knees, 168, 172
 timber (ribs), 168
Boat equipment, 172, 174–177
 axes, 174
 bailer, 174
 boat hooks, 174, 176
 buckets, 174
 compass, 175
 crutches, 172
 dippers, 176
 drinking vessels, 176
 engine tools, 175
 exposure cover, 175
 fire extinguisher, 175
 first aid outfit, 176, 211
 fishing tackle, 176
 heliograph (daylight signal mirror), 174, 209
 jack knife, 174
 manual pump, 174
 oars, 174
 oil bag, 175
 painters, 175, 188
 pyrotechnics, 174
 radar reflector, 175
 rations, 176
 rescue coit, 174
 rescue signal table, 175, 177
 sea anchor, 174, 175
 search light, 176
 steering oar, 174
 survival manual, 174
 thermal protective aids, 176
 torch, 174
 water container, 173, 176
 whistle, 174
Boat fitments, 172, 186
 automatic bailing, 187

- Boat fitments (*Contd*)
 drain valves, 186
 lamp, 187
 lifeboat engine, 178, 179
 mast and sails, 188
 rowlocks, 172
 rudder and tiller, 187
 skates, 173
 thole pins, 173
 watertight lockers, 173
- Boat launching procedures, 183, 191–195
 boat operations, 196
 beaching, 198, 199
 boat handling, 200
 boat recovery, 197, 198
 goose winging, 202, 203
 gybing, 202
 heaving to, 175
 reefing, 202, 203
 running, 202
 sail terms, 6, 203
 sail theory, 201–203
 tacking, 201
 wearing, 201, 202
- Boat rigging, 188
 buoyant lifeline, 189
 bowsing tackles, 190
 gripes, 191
 keel grab lines, 189
 lifeboat falls, 86, 88, 189, 190
 lifelines, 189
 mast and sail rig, 188
 painters, 188, 189
 tricing pennants, 190, 191
- Boatwork, 166
 access into lifeboats, 167
 lifeboat buoyancy, 167
 lifeboat construction, 166, 168
 lifeboat markings, 168
- Bolster, 34
 Booby hatch, 144
 Boom, 106
 Boss plate, 6
 Bosuns chair rigging, 71, 73
 Bottle screws, 89, 90
 Boulevart eye splice, 93–96
 Bow stopper, 33, 35, 37
 Bow visor, 163
 Breadth, 3
 Breaking stress
 (cordage, wire, and chain), 83
 Broken stowage, 152
 Bruce anchor, 57, 58
- Bulb angle/plate, 20
 Bulk cargoes, 146, 155
 coal, 155
 edible oil, 155
 scrap metal, 150
 deep tank stowage, 146
- Bulk carrier, 12
 Bulkhead, 19
 collision, 4, 6
 Bulldog (rope) grip, 90
 Bulwark, 17
 Bull wire, 107, 146
 Butterfly rig, 113, 114
- Cable, 29, 33
 clench, 38, 42
 drum, 33, 38
 holder, 35, 38
 jack, 38, 42
 laid rope, 62
 locker, 33, 34
 locker lashing, 41
- Camber, 2, 3
 Cantons, upper and lower, 257
 Capstan, 37
 Cargo handling procedure, 156
 can hooks, 159
 nets, 157
 plans, 164
 plate clamps, 157, 158
 runner, 107, 108, 110, 113
 slings, 157, 158, 159
 snotters, 156
 timber dogs, 157, 158
 vessel, 7, 17
 working, 153–165
- Carrick bend, 68, 69
 Carvel, 171
 Catspaw, 69
 Ceiling, 17, 145
 Cellular double bottom, 7, 145
 Centre of buoyancy, 5
 Centre of floatation, 5
 Centre of gravity, 5
 Chain block, 103–105
 Chain cable, 29, 31
 hook, 38, 42
 tests, 29
 types, 30
- Chain preventor, 107
 Channel bar, 20
 Cheek plates, 99
- Cheese rope, 81
 Chemical carrier, 11
 Chinese stopper (West Country), 80
 Clear, 93
 Clew, 201
 Clinker, 171
 Close up, 203
 Close reach, 203
 Clove hitch, 69
 Coefficient of fineness, 5
 Coffin plate, 6
 Coir rope, 61
 Collision bulkhead, 4
 Common link, 33, 40
 Common whipping, 77, 78
 Communications, 245
 Compressor, 33, 35
 Conical sockets, 90
 Container tonnage, 162
 Conventional hatch, 142, 143
 Copra, 155
 Courtesy ensign, 258
 Cow hitch, 81
 Cowl ventilator, 159
 Coxwain's responsibilities, 192, 200
 CQR anchor, 25, 26
 Cranes, 121, 122
 Cross, 43
 Cross head, 90
 Cross lay, 84
 Crown, 26
 Crutches, 172
- Danforth anchor, 26, 27
 Dangers—open boats, 201
 Davit launched liferaft, 216
 Davits, 169, 185, 191, 193
 Deadweight, 6
 Deadweight cargo, 152
 Deadwood, 168
 Deck, 4
 Deck cranes, 121, 123, 124
 Deep tanks, 146
 Deep tank cargo, 160
 coconut oil, 161, 162
 tallow, 161, 162
 whale oil, 161, 162
 Deep water anchoring, 49
 Depth, 3
 Derricks, 106
 calculations, 127–141
 crutch, 108, 109

- Derricks (*Contd*)
 hallen, 115, 116
 heavy lift, 118–121
 heel block, 107, 108
 operational hand signals, 127, 128
 single swinging, 107, 108
 stulken, 121
 tests and surveys, 125
 topping lifts, 107–110
 union rig, 110–112
 velle, 116, 117
 Devils claw, 33, 38
 Dewpoint, 159
 Dip (flags), 259
 Dipping ensign, 259
 Displacement, 5
 light displacement, 5
 load displacement, 5
 tonnage, 5
 Dolly winch, 107
 Double bottom tanks, 17, 145
 Double diagonal, 171, 172
 Double luff tackle, 102
 Double up procedure, 113
 Doubler, 34
 Dovetail chamber, 31
 Dragging anchor, 47, 48
 Drain valves, 186
 Draught, 3
 Draw bolt, 218
 Drift, 31, 38
 Drills, 242, 243
 'D' ring HRU, 218
 Drop test, 27
 Dry dock stresses, 21
 Duck bill fitment, 100
 Duct keel, 17
 Dunnage, 152

 Eccentric wheels, 148
 Edible oil, 155
 Efficient deck hand, 264
 Eight strand plaited, 62
 Elbow, 43
 Embarkation ladders, 193, 195
 Emergency alarm, 240, 241
 Emergency communications, 240
 Empirical formula, 132
 Enclosed lifeboats, 179–185
 Engine (lifeboat), 178, 179
 Engine room, 14
 Ensigns, 257

 blue, 258, 259
 red, 259
 white, 257
 EPIRB's, 246, 247
 Epoxy coating, 9
 Equal lay, 84
 Equilibrium, 5, 6
 Evacuation systems, 225–227
 Exposure cover, 175
 Extra flexible steel wire rope, 83
 Eye bolt, 91
 Eye splice (rope), 76
 Eye splice (wire), 93, 94, 95

 Fairlead, 35
 Feral, 92
 Fid, 74
 Figure '8' knot, 69, 70
 Filler, 171
 Fire protected boats, 179–187
 First aid outfit, 211
 Fishermans bend, 70
 Flag maintenance, 257, 258
 Flag recognition, 251, 252
 Flag signalling, 249–256
 Flags: courtesy, house, 258
 Flake, 81
 Flare, 3
 Flat seizing, 73, 74
 Flexible steel wire rope, 83
 Float free arrangements, 220
 Floating block, 190, 197
 Floor, 17, 19
 Flotation, 5
 Flour cargo, 156
 Fly, 199, 202
 Foot, 201
 Fore and aft line, 4
 Forestay, 86, 188
 Foul anchor, 43
 Foul hawse, 43, 50–52
 Frame, 17, 19
 Freeboard, 3
 Free fall lifeboats, 183
 Friction allowance, 130
 Fruit cargo, 156

 Gaff, 6, 259
 Gangboard, 168
 Ganger length, 33, 54
 Garboard strake, 168

 General cargo terminology, 152, 153
 General cargo vessel, 7, 17, 142, 164
 General emergency alarm, 240
 'G' flag, 250, 251, 258
 G gravity, centre of, 5
 Girders, 19
 Glass cargo, 156
 GMDSS, 245, 246
 GM–metacentric height, 6
 Gooseneck, 107, 132
 Goosewinging, 202, 203
 Grain, 154
 Grain space, 152
 Gravity davits, 191, 192
 Grease recess, 99
 Gripe, 191
 Gripe sheave, 191
 Grommet, 175
 Gross tonnage, 5, 24
 Grow, 43
 Guillotine bar, 35
 Gun tackle, 101
 Gunwale, 168
 Gunwale capping, 168
 Gunwale chock, 168
 Gusset plate, 17
 Guy, preventor, 110, 113
 Guys–slewing, 107, 111, 112
 Gyn, 127
 Gyn tackle, 103
 Gypsy, 43

 Hallen derrick, 115, 116
 Halls stockless anchor, 26
 Halyard, 65
 Hand signals for lifting operations, 128
 Handy billy, 101
 Hanging off an anchor, 53, 54
 Hambroline/houseline, 63
 Hard eye, 76, 92
 Hard laid rope, 62
 Hardwood chock, 108
 Hat box, 146
 Hatch, 17, 142
 board, 142, 143
 chain pull, 146
 construction, 143
 conventional, 142–145
 covers, 142–156
 slabs, 142
 steel/hydraulic, 146–152
 tents, 144, 145

- Hatchway, 143
 Hawse pipe, 33, 34, 163
 Hawser lay, 60, 62
 'H' bar, 20
 Head, 99
 Head block, 100
 Heart (of wire), 85
 Heaving too, 175
 Heavy lift, 118–121
 Heel block, 107
 Heel of mast, 188
 Heel tackles, 126
 Heliograph, 209
 Hemp rope, 61
 Hitches, 67–73
 Hogging, 22
 Hog piece, 168, 171
 Hold, 17
 ceiling, 17
 construction, 17
 preparation, 154
 Home, anchor coming, 42
 Houndsband, 89, 188
 Hove in sight, 43
 Hydraulic mooring winch, 36
- Immersion suits, 233–236
 Inflatable lifejackets, 229–231
 Inflatable liferaft, 204–228
 Inflated rescue boat, 237, 238
 Inglefield clip, 257
 In irons, 203
 Inner bottom longitudinals, 17
 Insulation material, 159
 Intercostals, 17
 International code of signals, 250, 251
 International conference on loadlines, 23
- Jack, 148
 Jaw (rope), 59
 Jaw (shackle), 32
 Jib, 6, 124, 201
 Jigger, 102
 Joggled plate, 17
 Joggle shackle, 44
 Jubilee clip, 51
 Jumbo derrick, 91, 119
 Jumper stay, 89
- Kedging, 44
- Keel, 168, 171
 grabline, 189
 rake, 4
 Keelson, 168, 171
 Kenter joining shackle, 30, 31
 King beam, 143
 Knee, 17, 168
- Langs lay, 84
 Lanyard, 172
 Lashing cables, 50, 51
 Launching, 191–196
 lifeboat procedures, 191–193
 stations, 193
 rescue boats, 237–240
 Laying out anchors, 49
 Lay of rope, 59, 62, 80, 84
 Lead block, 107, 108, 120
 Leadline, 64
 Lead pellet, 31
 Leech, 201
 Length, 3
 between perpendiculars, 3
 on waterline, 3
 overall, 3
 Length of lay, 62, 84
 Letting go anchors, 34
 Lifeboat (*see also* boat construction and boatwork), 166
 engine, 178
 equipment, 174–177
 falls, 189, 190
 question and answer, 266–268
 Lifebuoy specifications, 231–233
 Life jacket requirements, 229
 Life jacket lights, 230
 Lifelines, 189
 Liferaft, 204–229
 capacity, 208
 construction, 204, 206, 221
 davit launched, 214–218
 equipment, 208–211
 fittings, 207, 221
 float free arrangement, 218–221
 launching of, 211, 212
 markings, 208, 211, 213
 stowage, 210, 228
 Lightening holes, 17, 18
 Limber boards, 145
 Liner, 17
 Load deadweight, 6
 Loadlines, 23, 24
- Load stresses, 20, 21, 22
 Locking bar, 144
 Locking splice, 93–95
 Logline, 64
 Longitudinal girders, 17, 20
 Longitudinals, 17, 18
 Long splice, 76, 77
 Long stay, 44
 Loss of anchor, 55–57
 Loss of windlass power, 52, 53
 Lower hold, 17
 Lowering hitch, 73
 Lowering turns, 73
 Lubrication (wires), 85
 Luff, 201, 203
 Luff tackle, 102, 103
 Lug, 32
 Lugged joining shackle, 32, 33, 40
 Lugless joining shackle, 30, 31, 40
 Lumber loadline, 24
- Macgregor steel hatches, 146–152
 Main halyard, 188
 Main mast, 6, 188
 Main sail, 6, 201
 Main staysail, 6
 Main topsail, 6
 Maintenance of
 blocks, 99
 flags, 256, 257
 lifeboats, 184
 planned, 82, 112
 Manhelper, 51
 Manilla rope, 59
 Mast truck, 254
 Marine evacuation system, 225–227
 Marking anchor cable, 40
 Marking of anchors, 29
 Marking of sails, 201
 Margin plate, 17, 145
 Marline, 63, 64
 Marline spike hitch, 69, 70
 Marry two ropes, 78
 Martingale, 126
 Mast, 6, 188
 clamp, 188
 house, 120
 main, 6
 mizzen, 6
 rigging, 188
 step, 188
 thwart, 188

SHIPHANDLING

314

Index to part one

- Measurement cargo, 153
Measurement (rope and wire), 86
Mechanical advantage, 101, 102
Messenger, 50
Metacentre, 5
Metacentric height, 5, 6
Metal blocks, 99, 100
Midshipmans hitch, 70
Mills atlas release, 217
Mizzen topmast staysail, 6
Mooring, 44
 anchors, 57, 58
 new rope, 81
 shackle, 58
 wire, 88, 97
Morse code, 261
Morse procedure, 260–262
Moulded dimensions, 3
 breadth, 3
 depth, 2, 3
Mousing hook and shackles, 97, 98
Moving block, 101, 190, 197
Multi-fold hatches, 151, 152
Muster lists, 241
Muster signals, 240, 268
- Natural fibre rope, 59
Naval pipes, 45
Net tonnage, 5
Non-return valve, 145
Numeral flags, 252
Numerals morse, 261
Nylon rope, 65
Nylon strop, 197
- Oars, 174
Offshore supply craft, 13
Oil bag, 175
Oil fuel tanks, 7, 15, 180
Oil separator pump, 15
Oily/water separator, 15
Open boat dangers, 201
Open hatchway, 150
Opening hatches, 142–152
Opening new ropes, 81
Opening new wires, 97
Open link, 34, 39
Oxter plate, 18
- Pad eye, 91
Painter, 174, 184, 192, 196
Painter shackle, 168
Palletisation, 156, 157
- Palm and needle whipping, 78
Palm oil, 162
Panting beams, 18
Panting stringers, 18
Parceling, 75, 76
Partially enclosed boats, 180, 186
Passenger car ferry, 8
Passenger ships, 181
Pay off, 203
Peak, 201
Pear link, 111
Perpendiculars, 3
Phonetic alphabet, 260
Pillars, 19
Plain laid, 63
Plaited rope, 62
Plan for anchoring, 38, 39
Plate clamps and dogs, 157, 158
Plate landings, 17, 18
Pneumatic windlass, 36
Point line, 64
Polyester, 66
Polypropylene, 66
Pontoon covers, 150
Performing, 85, 86
Preparation of anchors, 34, 38, 40
Preventor, 91
 backstay, 91
 guys, 108, 110, 111
 wire, 111
Procedure for anchoring, 38, 39
Product carrier, 9
Proof load
 anchors, 28
 cable, 31
 derricks, 125
Punch and drift, 31
Purchase (tackle), 100
 advantage, 101, 102
 calculations, 130–141
 differential, 105
 friction allowance, 101, 130
 gun tackle, 101
 gyn tackle, 103
 handy billy, 101
 jigger, 102
 luff (single and double), 102, 103
 three fold, 103
Pyrotechnics, 174
- ‘Q’ Flag, 250, 251
Quarter, 2
Queen beam, 143
- Quick link, 91
Quoins, 155
- Rack and pinion hatches, 150
Racking seizing, 74
Racking stresses, 21
Raft release gear, 218–221, 228
Raised strakes, 17
Rake of keel, 4
Ramp, 163
Rations, 210
Ratline, 64
Reach, 203
Ream, 44
Recovering anchors, 52, 53
Recovering boats, 197, 198
Red ensign, 259
Reefer cargo, 158–160
Reefer ship, 12
Reefing sails, 202, 203
Reef knot, 70, 71
Refrigerants, 159
Release gear-boats, 184, 185
Render cable, 44
Rescue boats, 237
 equipment, 238, 239
 requirements, 238
Re-securing anchors, 55–57
Reserve buoyancy, 6
Rib (timber), 168
Riding cable, 50, 52
Rigging, 82
 bosuns chair, 71, 73
 derricks, 106–112
 fid, 74, 75
 fitments, 91
 gyn, 127
 heavy lift derrick, 118–121
 running, 86, 88
 screw, 89, 90
 sheer legs, 126
 stage, 73
 standing, 86, 87
Right ahead, 2
Right astern, 2
Right hand laid rope, 62
Righting capsized craft, 183
 lifeboats, 189
 liferaft, 227
Rigid liferafts, 212
 access, 212
 capacity, 213
 construction, 212

- Rigid liferafts (*Contd*)
 davit launched, 214
 fittings, 213
 markings, 213
Rise of floor, 4
Rising, 172
Rogues yarn, 188
Rolling hitch, 70
Roll-on, roll-off, 162, 163
Roll-on, roll-off ship, 10, 13
Rolltite hatches, 152
Ropework, 59
 rope gauge, 86
 rope lay, 62, 84
Roping twine, 65
Rose seizing, 74
Round eye, 100
Round turn and two half hitches, 70, 71
Rowlock, 172
Royal standard, 257, 258
Rubbing strake, 168, 172
Rudder, 187
Runner, 107
Running bowline, 67, 68
- Safe handling of derricks, 112, 113
Safety supply/craft, 13
Sagging, 22
Sail, 6, 201
 marks on, 201
 parts of, 201
 terms, 6, 203
 theory, 201–203
 types, 6, 201
Sailmakers whipping, 77, 78
Samson post, 119
SART, 247, 248
Scantlines, 18
Schooner, 6
Scope, 44
Score, 93
Scotsman, 38
Screw eye bolt, 91, 92
Scuppers, 154
Sea anchor, 174, 175
Seaming twine, 64
Seattle hook, 110
Securing anchors to cable, 33
Securing hatches, 144
Securing Ro Ro cargo, 164
Seizings, 74
Seizing wire, 40, 85, 98
- Senhouse slip, 92
Sennet laid rope, 63
Serving, 75
 board, 75
 mallet, 75
Setting fid, 75
Service of
 hydrostatic release, 221
 liferafts, 228
Shackle
 joining, 30–33
 length, 44
 mousing, 97, 98
 parts of, 32
Shank, 25
Shearing stresses, 21
Sheaves, 98, 99
Shell plate, 17
Sheepshank, 71
Sheer, 3, 44
Sheer legs, 125, 126
Sheer strake, 19
Sheet anchor, 45
Sheetbend, 71
Ship, 1
 construction, 17, 20
 dimensions, 3
 stresses, 20, 21
 terms, 1–7
 types, 7–17
Shorten cable, 45
Short stay, 45
Shroud, 89, 90
Shroud laid rope, 62
Side bench, 168
Side frame, 17
Signal halyard, 65
Signal letters, 249
Signals, 250–256
Single anchor procedure, 39
Single letter meanings, 250
Single span derrick, 107
Single swinging derrick, 106, 107
Sisal rope, 60
Size of cable, 30
Size of rope, 86
Skates, 173
Sleeping cable, 51
Slewing guys, 111, 112
Slings, 72
Slip wire, 97
Small gear locker, 173
Small stuff, 63
- Snotters, 156
Snub, 45
Snug, 35, 38
Sockets, 90, 91
Soft laid rope, 62
Solid thimble, 92
Span block, 108
Spare anchor, 55
Spar ceiling, 150, 152, 154
Special cargoes, 154
Specifications
 lifebuoys, 231
 lifejackets, 229
Spider band, 107, 113
Spile pin, 31
Splay tackles, 126
Splices, 76, 93
 back, 76
 eye, 76, 93–95
 long, 76, 77
 short, 76, 77
Spreader, 158
Spring lay, 84, 85
Spun yarn, 64
Spurling pipe, 33, 35, 45
Stability expressions, 5, 6
Stage rigging, 73
Standard laid rope, 63
Standing block, 101
Standing rigging, 86, 87
Stay
 backstay, 91
 forestay, 86
 jumper, 89
 topmast, 86, 89
 triatic, 89
Staysail, 6
Stealer plate, 19
Steam guys, 118
Steam windlass, 34
Steel hatch covers, 146–156
Steel wire rope, 82, 83
Steering flat, 4
Steering oar, 174
Stem, 168
Stem band, 168
Stem post, 168
Stern, 12
Stern door, 10
Stern post, 168
Stock, 4, 25, 26, 58
Stockholm tar, 75
Stockless anchor, 25, 26

SHIPHANDLING

316

Index to part one

- Stoppers, 79, 80
 chain, 80, 81
 common, 79, 80
 West Country, 80
- Stowage
 factor, 153
 methods, 155
 wires on reels, 96, 97
- Strakes, 17
- Strand of rope, 59
- Stresses on derricks, 129–141
- Stretchers, 172
- Strops, 157
- Strum box, 145
- Stud, 31
- Stud eye, 100
- Stulken derrick, 121
- Summer loadline, 22, 23
- Surge, 45
- Survival craft, 204
- Survival manual, 174, 243
- Swallow, 98
- Swifter, 90
- Swivel head, 100
- Synthetic fibre rope, 65
- Tabernacle, 121
- Tack, 201
- Tacking, 201
- Tackles, 100–103
- Tackline, 249
- Talurit clamp, 92
- Tank cleading, 168
- Tank coatings, 9
- Tanker, 10, 165
- Tanker cargo plans, 164, 165
- Tank side bracket, 17, 145
- Tank top, 17, 145
 ceiling, 145
- ‘T’ bulb, 20
- Tarpaulins, 142–144
- Terms and definitions, 1–7
- Tests
 on anchors, 27
 on cable, 29
 on derricks, 125
- Thermal protective aids, 236
- Thimbles, 92, 93
- Thole pins, 173
- Three fold purchase, 103
- Thwart, 168, 172
- Thwart knee, 168
- Tide rode, 45
- Timber dogs, 157, 158
- Timber hitch, 70, 71
- Timber loadline, 24
- Timbers, 168
- Tonnage, 5
- Topmast stay, 86, 89
- Topsail, 6
- Topping derricks, 108–110
- Topping lift, 108, 109
- Totally enclosed boats, 180–204
 air support system, 184
 capacity, 181
 fire protection, 182, 184
 launching, 185, 196
 release mechanism, 183, 184, 185
 requirements, 182, 183
 water spray system, 184
- Training manual, 243, 244
- Transit bearings, 47
- Traveler, 188
- Triangular plate, 92
- Triatic stay, 89
- Tricing line, 215
- Tricing pendant, 190, 191
- Trigger, 191
- Tripping line, 175
- Tripping palms, 26
- Tropical fresh loadline, 22, 24
- Tropical loadline, 22, 24
- Trunnion, 120
- Tumblehome, 3
- Tumbler, 108
- Turnbuckle, 89
- Turn of bilge, 145
- Two letter signals, 255, 256
- Tyzack bar, 20, 143
- ‘U’ bolt, 112
- Ullage, 161
- Underdeck girders, 143
- Union hook, 110
- Union plate, 92
- Union purchase, 110–113
- Unit loads, 162–164
- Unstable, 5, 6
- Up and down, 45
- Upper block, 101
- Upper deck, 4, 7
- Upper tween deck, 7
- Veer cable, 45
- Vehicle stowage, 163, 164
- VHF use, 48
- Velle derrick, 116, 117
- Ventilators, 159
- Ventilation, 158, 159
- Warp threads, 257
- Watch at anchor, 46–48
- Water lay, 62
- Water pressure, 21
- Weak link, 218, 219
- Wearing, 201, 202
- Weft thread, 257
- Whippings, 77–79
- Winches, 36, 37
- Windlass, 33, 35, 36
- Wind rode, 45
- Winter loadline, 22
- Wire work, 82
- Wire rope, 83
- Yard, 254
- ‘Y’ mast, 115
- Yo-yo rig, 114
- ‘Z’ bar, 20
- ‘Z’ cargo block, 99

SHIPHANDLING

INDEX TO PART TWO



- Abandonment, 141–143
Abbreviations (IAMSAR), 209
Absolute temperature, 62
Accidents aboard tankers, 261, 263, 267
Accommodation fires, 168, 169
Accommodation ladder, 16, 19
Action of distress vessel, 189, 190
Active fin stabilisers, 225, 226
Adjustment of sextant, 32–34
Admiralty list of lights, 9, 11
 list of radio signals, 9, 11
 sailing directions, 9, 11
 tide tables, 9, 11
 weekly notices to mariners, 9, 10
Advance, 219–222
Advice for helmsman and OOW, 219
Aeration–echo sounder, 28
Aground, 110, 131, 145–147
Aircraft carrier, 126
Aircraft in distress, 192
Air cushion vessel, 126, 127
Alternative towing, 246
AMVER, 206–209, 299
Anabatic wind, 57
Anchor ice, 78
Anchor types, 275, 289
Anchor, use of, 75, 105, 109, 240
Anchoring, in emergency, 240
Anchoring large vessels, 274
Anemometer, 57
Aneroid barometer, 53–56, 57
Annual summary of notices to mariners,
 9, 10
Anschutz–gyro compass, 38–40
Anti-cyclone, 57
Arc of sextant, 30
Arming the lead, 26
Athwartships magnets, 41, 43
Atlantic weather areas, 66
Aurora, 57
AUSREP, 208
Automatic pilot, 6
Automatic resuscitation equipment, 266
Auxiliary steering gear, 163
Azimuth mirror, 48–50
Backing, 57
Balanced rudder, 213
Ballast, 254, 259
Baltic moor, 237, 238
Bar, 58
Bare ice, 78
Barograph, 56, 58
Barometer–aneroid, 55
Barometric tendency, 58
BCF (extinguishing agent), 181
 (bromochlorodifluoromethane), 181
Beaching, 145–148, 301
Beating out to seaward, 77
Beaufort weather notation, 68, 69
Beaufort wind scale, 67
Behaviour of vessels in heavy weather,
 72–75
Bells (ships), 123
Benefit of the lead, 26
Bergy bit, 78
Berthing, 230–231
Binnacle, 41–43
Black oils, 250
Blockage factor, 243
Boiler flue gases, 273
Bollards (bitts), 227, 229
Boundary cooling, 174, 177, 179, 290
Bow/stern thrusters, 223–225
Brash ice, 78
Breast line, 227
Breathing apparatus, 183–185, 266
Breeches buoy, 196, 200, 201, 202
Bridge, 2, 6
Bridge layout, 2
Bridge wing lifebelt, 153, 154
Bridle (gangway), 16
Broach to, 74
Bulk cargo fires, 175
Bulk oil, 175
Bullring, 248
Bulwark ladder, 17
Buoyage IALA system A and B, 132–136,
 295
Buoyant smoke float, 199
Buoys–letting go from and securing, 136,
 232, 233
Butterworth (tank cleaning) machines,
 259, 260
Calling Master, 4, 5
Canal speed, 241, 242
Carbon dioxide CO₂ flooding, 178–181,
 187, 188, 251, 289
Cardinal marks, 134
Cargo fires, 185–188
Cargo (oil) handling equipment, 255
Cargo tank ventilation, 263, 264
Carriage of dangerous goods in ships, 14
Casualty rescue, 267
Cavitation, 210, 214
Centering error, 34
Certificates, 292–295
Chafing chain, 248
Chain bridle, 246
Checklist for passage appraisal, 2
Chemical fire extinguisher, 170
Chernikeeff log, 24
Chronometers, 35, 36
Clamp of sextant, 30

- Class of fire, 167
 Clean oils, 250
 Clearing berth, 230, 231
 CO₂ gas, 178–181, 187, 188, 251
 Coal fire, 186, 187
 Coastal forecast areas, 65, 70
 Coastguard services, 204–206
 Coastguard stations UK, 205
 Code of safe working practice, 9
 Code of safe working practice bulk cargoes, 10
 Cold front, 58
 Collimation error, 32, 34
 Collision, 137–141, 298
 Masters obligations, 137, 138, 298
 patch, 140
 Combined jet spray, 178
 Communications
 coastguard, 203, 204
 distress, 191, 192
 helicopters, 159, 299
 Compact ice edge, 78
 Compact pack ice, 78
 Compass, 37, 43
 bowl, 42, 43, 45
 card, 43
 correction, 46
 gyro, 36–40
 magnetic (dry card), 48
 magnetic (liquid), 42, 44, 45
 swing, 300
 Composite towline, 247
 Compulsory insurance, 278, 279
 Con, 210
 Concentration of ice, 78
 Condensation, 58
 Conduction, 58
 Consolidated pack ice, 78
 Constrained by draught, 95, 104, 108
 Construction of lead line, 25
 Construction of synoptic chart, 66
 Contingency plans, heavy weather, 69, 70
 Controllable factors of ship handling, 212
 Controllable pitch propeller, 215–217
 Convection, 58
 Corona, 58
 Correction of sextant, 32–34, 289
 Cotton fires, 186
 Crack in ice, 78
 Crash stop, 211
 Crude oil washing, 259–261
 Cyclone, 58
 Damage assessment, 137, 147, 302
 Damage stability data, 137
 Dangerous semi-circle, 76, 77
 Day signals, 121
 Dead beat compass, 44, 289
 Deck checklist following:
 beaching, 147
 grounding, 147
 Deck officers duties, 258–261
 tanker loading/discharging, 258, 259
 Deck seal (water), 272
 Deep draughted vessels, 95, 108, 291, 292
 Deep scattering layer, 29
 Deep tank fires, 176
 Degrees of freedom (gyro), 36
 Delayed turn, 155
 Density, 52, 53
 Department of Trade and Industry gangway, 19
 Depression, 71
 De-rat certificate, 292
 Deviation, 186
 Dew, 59
 Dew point, 59
 Diameter (of turning circles), 219, 221, 222
 Difficult ice area, 78
 Diffraction, 59
 Direction of buoyage, 136
 Dirty ballast, 254
 Distress, 191
 action by distressed vessel, 189–190
 Masters obligations, 190
 message, 192
 receipt of distress, 190, 191, 207, 208, 297
 signals, 114, 123, 197–201
 Dock water allowance, 52, 53
 Docking tug, 242, 245
 Doldrums, 59
 Double dunnage, 187, 188
 Double echo, 29
 Double turn, 155, 156
 Drag, 210
 Dredging down, 238
 Drift angle, 219, 223
 Drills, 141, 142
 Dry card compass, 48
 Dry dock–chief officers duty, 150, 151, 289
 Dry dock plan, 152
 Dry dock procedures, 150–153
 Dry dock–shore positions, 152
 Dry powder extinguisher, 167, 170
 Ducting, about propellers, 214
 Duties of:
 helmsman, 6, 7, 8, 211
 lookout, 5, 6, 88
 officer of watch, 3, 4, 8, 9
 stand-by man, 8, 9
 Dust explosions, 176
 Easy (ice) area, 78
 Echo sounding, 26–29
 errors, 28
 false echoes, 28, 29
 Elastic membrane (compass), 43
 Elliot White Gill–thrust units, 223–225
 Emergencies, 137
 Emergency, 137
 anchoring, 240
 boats crew, 154
 bridge lifebuoy, 153, 154
 plans and procedures, 252
 signals, 137, 153
 towing, 247, 248
 Enclosed spaces, 266–269
 Engine distance, 218
 Engine room department
 checks following grounding, 146, 147
 or beaching, 146, 147
 Englefield clip, 21–23
 Entering docks and locks, 232
 Entries into oil record book, 13
 EPIRB's, 193
 Errors of marine sextant, 32–34
 Escape sets, 266
 Etesian wind, 59
 Evacuation methods, 157
 Evaporation, 45, 59
 Evasive action for bad weather, 77
 Even keel (turning), 220
 Examination of pilot hoists, 17, 18
 Expansion chamber (compass bowl), 289
 Explosimeter, 250
 Explosions, 136, 252
 Explosive limits, 250, 252
 Explosives, 14
 Extinguishers, 167, 170
 Extinguishing agents, 167

- Fairleads, 227, 228
 False bottom, 28
 False echoes, 28
 Fans, 264
 Fast ice, 78, 79
 Fenders, 150, 232
 Final diameter, 219
 Fine on the bow, 5, 73
 Fin stabilizer control, 226
 Fin stabilizers, 225, 226
 Fire, 166
 Fire and explosion, 250
 Fire detection unit, 2
 Fire doors, 173
 Fire example cargoes, 185–188
 coal, 186, 187
 cotton, 185, 186
 fish meal, 187, 188
 LNG, 185
 Fire examples, 168–188
 accommodation, 168, 169
 cargo spaces, 174–177
 galley, 169–171
 machinery space, 171–173
 paint room, 177, 178
 small, 166
 triangle, 171
 Fire fighters, 166
 Fire fighting, 166
 First adjustment–sextant, 32
 First year ice, 79
 Fish meal cargo, 187, 188
 Fixed fire fighting installations, 178–182, 250
 BCF, 181, 182, 251
 carbon dioxide CO₂, 179–182, 251
 dry powder, 185, 251
 foam, 178, 250, 251
 steam smothering, 179, 251
 Fishing nets, 291
 Fishing vessels, 102, 103
 Fishing vessel signals, 103, 120, 121
 Fixed blade propeller, 215, 216
 Flame proof gauze, 255
 Flammable liquids, 14
 Flap rudder, 214
 Flashpoint, 249
 Flaw (ice), 79
 Flinders bar, 43, 46
 Floating ice, 79
 Floating link, 162
 Floe (ice), 79
 Floeberg, 79
 Flooding, 139, 140
 Foam extinguisher, 170
 Foam fixed extinguisher, 251
 Fog, 59, 304, 305
 Following sea, 74
 Forecast areas, 64, 65
 Fracture (ice), 79
 Frame of sextant, 30, 31
 Free gyroscope, 36, 37
 Fresh water allowance, 53
 Frog, 22, 23
 Fronts, 69
 Fusee drum, 35
 Ganger length, 238
 Gangway (DoT), 19
 Gangways, 19
 Gale, 59, 67
 Galley fire, 169, 171
 Gas detector, 267
 Gas lines, 254
 Gas protection suit, 266
 Gather way, 212
 General declaration, 147
 General duty–watchkeeping, 3, 5–9
 General (tanker) operations, 249
 Gimbals, 35, 36, 45, 46
 Girding (girding) a tug, 243, 245
 Glacier, 79
 Gnomonic projection, 295
 Gob rope, 244, 245
 Gong, 123
 Governor, 21, 22
 Graduation error, 34
 Grey ice, 79
 Grounded ice, 79
 Grounding, 145
 Growler, 80
 Guest warp, 144
 Guidelines–marine safety card No. 1, 268–271
 Guide line, use of, 267
 Gulf stream, 59
 Gyro compass, 36–40
 Gyroscopic inertia, 37
 Hail, 59
 Halo, 60
 Halon, 178, 181–182
 Hand flare, 198
 Hand lead, 25
 Hand smoke, 200
 ‘Hand’ the log, 23
 Hawser (breeches buoy), 201, 202
 Haze, 60
 Head lines, 227
 Heading how is she, 124
 Head on situations, 94
 Headreach, 210
 Health and safety (aboard tankers), 261–263
 Heat shield, 175, 177
 Heaving to, 74, 300
 Heavy weather, 69, 71, 72–77
 Heeling error magnets, 46
 Helicopter procedures, 156–161, 299
 Helicopter strop, 159
 Helm orders, 8
 Helmsman, 6, 7, 210
 advice, 6, 7, 219
 duties, 6, 7, 8
 HM Coastguard, 204, 205
 Hoists, 17
 Horizon mirror, 32
 Horizontal magnets, 46
 Horse latitudes, 60
 Hose action, 174–178
 Hose boxes, 173
 Hovercraft, 126, 127
 Humidity, 60
 Hummock ice, 80
 Hurricane, 60, 67, 76, 77
 Hydrants, 173
 Hydraulic steering, 161, 162
 Hydrocarbons, 264–267
 Hydrometer, 52–53, 60, 255
 Hygrometer, 53, 60
 IALA buoyage system, 132–136, 295
 IAMSAR, 10, 209
 Ice, 60
 damage, 84, 85
 navigation, 83–85
 strengthening, 84, 302
 terminology, 78
 types, 78–82
 Icing up, 67
 Ignition point, 252
 Ignition sources, 251, 252
 IMDG code, 14
 IMO, 86
 Impellor log, 24, 25
 Inclinator, 43

SHIPHANDLING

320

Index to part two

- Inconspicuous partly submerged object, 101
- Index arm, 30
- Index error, 32–34, 289
- Index mirror, 30, 32
- Indicator buoys (submarine), 164, 165, 297, 298
- Inert gas, 254, 264
- Inert gas systems, 269–274
- Inhalation of hydrocarbons, 265
- Instrument error, 34
- Insurance, 278, 279
- Insurance certificate, 279
- Insurance wire, 247
- Interaction, 240–244
- International code of signals (INTERCO), 10, 12, 209 (see Part 1, for flag recognition (identity))
- International shore connection, 183–185
- Intrinsically safe, 252
- Iridium pivot, 44, 48
- Isobars, 60
- Isolated danger buoy, 135
- Isotherms, 60
- Jack stay, 201
- Jayhawk helicopter, 160
- Jet/spray, 178
- Jumping buoys, 229
- Jury rudders, 161
- Jury steering, 163
- Katabatic wind, 61
- Keel, 153
- Keel blocks, 151, 152, 153
- Kerosene, 250
- Key (tail end shaft), 216
- KM (dry dock formula), 153
- Ladders, 15–20
- Land and sea breezes, 61
- Landing areas for helicopters, 157
- Landing-on helicopter checks, 160, 161
- Large tankers, 249 mooring, 274–276 towing arrangements, 247, 248
- Lateral marks, 133
- Lead (ice), 81
- Lead line, 25, 26
- Leadsman, 26
- Leakage, oil, 277, 278
- Letting go from buoys, 233
- Level ice, 81
- Lifeboat use, 194, 195, 196
- Liferaft use, 193, 195
- Light and smoke marker, 201
- Lightening, 252
- Light lists, 9, 11
- Lights (navigation), 97, 115–120
- Lines of magnetic force, 46
- Line throwing apparatus, 144, 194, 202, 203, 289
- List, 210, 222
- Liquid magnetic compass, 44–46, 289
- LNG fires, 185
- Loading (tanker) procedure, 276–278
- Local direction of buoyage, 136
- Location aids, 196–201, 203, 204
- Log, 21 impeller type, 24, 25 rotator type, 21–24
- Logline, 23, 24
- Long distance towing, 244
- Lookout, 9, 88 duty, 5, 6 field of view, 5, 291
- Loss of rudder, 161–163
- Lubber line, 47, 51
- Machinery space fires, 171–173
- Magnetic compass, 41–51
- Making way, 212
- Manifold, 254
- Manropes, 15
- Manoeuvring signals, 111
- Man overboard, 153–156, 294
- Marine instruments, 30
- Marine safety card No. 1, 270, 271
- Marine sextant, 30–34
- Mariners handbook, 11
- Maritime rescue co-ordination centres UK, 70
- Marks on lead line, 25
- Masons hygrometer, 53
- Masters' obligations in distress, 138, 190
- Masters responsibilities, 1
- Mechanical hoists, 17, 18
- Merchant shipping notices, 10
- Meteorological terms, 57–65
- Meteorology, 57–86
- Micrometer sextant, 30, 31
- Mine clearance vessels, 108
- Minerva fire detection unit, 2
- Mirage, 61
- Monsoon, 61
- Mooring, 233 Baltic moor, 237 Mediterranean moor, 238, 239 open moor, 236 running moor, 233, 234, 235 standing moor, 235–236
- Mooring lines, 227
- Mooring swivel, 236
- Mooring systems, 227, 275, 276
- Motive power, 220
- Multi angled fairlead, 227
- Multi-year ice, 81
- Narrow channels, 90, 241
- Nautical almanac, 12
- Nautical tables, 12
- Navigable semi-circle, 76
- Navigational warning, 191
- Navigational watchkeeping, 1–9
- New dangers, 295
- New ice, 81
- Nilas, 81
- Nip, 82
- Non-adjustable errors of sextant, 34
- Non-displacement craft, 128
- Non-persistent oil, 278
- Non-return valve, 272
- North Atlantic weather forecast areas, 66
- Notices to mariners, 9, 10
- Not under command, 103, 105
- Nozzles jet/spray type, 178
- Obligations of rescue craft, 190
- Officer (watchkeeping) duties, 3–6
- Official publications, 9–14
- Offshore anchor, 275, 289
- Offshore installation, 127
- Oil, 278 fires, 249 pollution, 276, 278–284 pollution manual, 10 pollution participating countries, 287 to the convention record book, 12, 13 references, 285, 286 residues, 279

- rigs/platforms, 127, 128
 tankers, 249, 250
 Oil water separator, 279
 Old man/deadman, 227
 On scene co-ordinator OSC, 204, 207–209
 Open moor, 236
 Open pack ice, 82
 Open water, 82
 Operating in ice conditions, 83, 84
 Overtaking, 93
 Oxygen analyzer, 265
 Oxygen-in fire, 171

 Pack ice, 82, 85
 Paint room fire, 177, 178
 Pair trawling, 121
 Panama lead, 228, 248
 Pancake ice, 82
 Passage appraisal, 2
 Passenger vessel emergency, 142, 143
 Patent rotator log, 21
 Pelorus, 50, 51
 Period of encounter, 71, 72
 Performance monitor (radar), 290
 Period of roll, 71, 72
 Permanent ballast, 254
 Persistent oil, 278
 Phosphorescence, 61
 Pilot books, 11
 Pilot hoists, 17–20
 Pilot ladders, 15–20
 Pilot vessels, 104, 105, 131
 Pilot wheels, 7
 Pipelines, 254, 262, 263
 Pitch (of propellers), 211, 219
 Pitching, 72
 Pivot (compass) point, 44
 Pivot point, 211
 Plug plan, 152
 Plugs, 151
 Polar front, 61
 Pollution, 276, 277
 incidents, 279
 precautions against, 276–281
 references, 285, 286
 regulations resume, 283
 Pooping, 73
 Pounding, 73
 Precession, 37
 Precipitation, 61, 71
 Precision aneroid barometer, 53–56
 Preferred channel marks, 133, 134

 Pressure vacuum breaker, 269
 Preventing collision at sea, 86
 Principle of echo sounder, 26–28
 Principle of sextant, 31
 Prismatic error, 34
 Production platforms, 127, 128
 Prohibition of oil discharge, 282, 283
 Propellers
 controllable pitch, 212, 216
 fixed pitch, 212, 215, 216, 240
 propeller removal, 150
 propeller slip, 217, 218
 Protective equipment, 266
 Pump room precautions, 266–271
 Pump room rescue, 267
 Purge pipe, 264
 Purse seiners, 120, 121
 Pyrotechnics, 196–201
 Pythagorean error, 28

 Quadrantal correctors, 43, 45, 46
 Quadrant steering, 163
 Quartermaster, 6, 211
 Quayside mooring, 227
 Questions and answers, 289–307

 Radar reflectors, 4, 136
 Radiation, 61
 Radio signals, 9, 11
 Rafted ice, 82
 Rain, 61
 Rainbow, 62
 Ranging (on moorings), 241
 Reaction fin, 214
 Reception of slops, 279
 Recurvature of storm, 62
 Reduction of speed, 90, 168
 Refined product carrier, 250
 Reflector (compass) unit, 47
 Refraction, 62
 Regulations, for the prevention of, 86
 Annex I, 115
 Annex, II, 120
 Annex, III, 121
 Annex, IV, 123
 Collision at sea, 88–88
 conduct of vessels in, 95
 Part A—General, 86–88
 Part B—Steering and sailing rules, 88–96
 Part C—Lights and shapes, 96–111
 Part D—Sound and light signals, 111–114
 Part E—Exemptions and annexes, 114, 115
 restricted visibility
 (Section I), 88
 (Section II), 93
 (Section III), 95
 Remote controlled craft, 129
 Rescue and recovery, 143–145
 Rescue of casualties, 172, 266, 267
 Restricted in ability to manoeuvre, 103, 106–107
 Ridge, 62
 Riding cable, 235, 236
 Rigging pilot ladders, 15–20
 Rigging slip wires, 228, 229
 Rigidity in space, 37
 Rocket line throwing gear, 202, 203
 Rocket parachute flare, 197
 Roller fairlead, 227, 228
 Roll-on, roll-off vessel emergency, 143, 195
 Rotary vane steering, 162
 Rotator log, 21–23
 Rotten ice, 82
 Rudders, 213
 angle, 222
 carrier, 163
 loss, 161–163
 stock, 163
 Rudder types, 213
 balanced, 213
 flap, 214
 plate, 213
 rotor, 214
 schilling, 214, 215
 semi-balanced, 213
 spade, 213
 un-balanced, 213
 Rule of the road: questions and answers, 129–132
 Safe entry, 266–271
 Safe handling tows, 243
 Safe port options, 140
 Safe speed, 88, 89
 Safe water mark, 135
 Safety checklist—helicopters, 156, 157, 159–160
 Safety construction certificate, 292, 293
 Safety equipment certificate, 292, 293

SHIPHANDLING

322

Index to part two

- Safety officer/safety committee, 306, 307
- Safety radio certificate, 292, 293
- Sailing directions, 9, 11
- Sailing vessels, 93, 102
- SART's, 191, 192, 209
- Schilling rudders, 214
- Scrambling nets, 143
- Screens (sidelights), 117
- Scrubbing tower, 273
- Sea anchors, 75, 76
- Sea ice, 82
- Seaplane, 111, 128
- Search and rescue operations, 191
- Search patterns, 191
- Sea-sickness medicine, 174, 210
- Securing propeller, 216
- Securing to buoys, 228, 229, 232, 233
- Separation schemes, 92
- Semi-balanced rudder, 214
- Set, 211
- Sextant, 30–34
- Shade error, 34
- Shadow pin, 50
- Shallow water effect, 241, 242
- Sheer, 211
- Ship handling
 - factors, 212
 - in ice conditions, 83, 84
- Ship/shore connection, 183
- Ship to shore (tanker) checklist, 253
- Shoring up bulkheads, 140
- Short round, 234
- Shoulder post, 246
- Side keel blocks, 152
- Sidelights, 99, 116, 117
- Sighting port spanner, 253, 256
- Single point mooring, 275, 276
- Skin contact by hydrocarbons, 264, 265
- Slack tanks, 276, 277
- Sleeping cable, 235, 236
- Sleet, 62
- Slip of propeller, 217, 218
- Slip wires/ropes, 228, 229
- Slops, 279
- Small fires, 166
- Smoke signals, 199–201
- Snow, 62
- Snubbing round, 239
- Sounding, 256
- Sounding rod, 255
- Sound signals, 121
- Spade rudder, 213
- Specialized carriers, 250
- Special cases to Rule of the Road, 125–127
- Special marks, 135
- Special operations Ro Ro vessel, 195
- Specific gravity, 255
- Sphere correctors, 43, 45, 46
- Spontaneous combustion, 177, 186, 187, 252
- Squall, 62
- Squat, 211
- Stabilizer fins, 226
- Stanchions, 15
- Standing moor, 235, 236
- Steam smothering, 179
- Steel tape measure, 255
- Steering gear, 161–163
 - failure, 163
 - types, 163
- Stern light, 97, 98
- Stern lines, 227
- Stern thruster, 223, 224
- Stern to sea, 73, 74
- Stevenson's screen, 53
- Stiff ships, 71, 73
- Stopping distance, 211
- Storm movement, 77
- Stowage factor, 291
- Stranded ice, 82
- Stranding, 145
- Stratosphere, 62
- Stuffing box, 163
- Sub-sunk buoys, 165
- Sub-sunk procedure, 164, 165
- Surface rescues, 193–196
- Surrounding a fire, 169
- Survivors, 143–145
- Swell, 68
- Synchronism, 72
- Synoptic weather chart, 71
- Tabular berg, 82
- Tackling a fire, 169
- Tactical diameter, 219
- Taking the ground, 145–147
- Tank, 256
 - cleaning, 260, 261
 - gauge, 257, 258
 - layout, 262, 263
 - lid, 262
 - lid plan, 262
 - measurement, 256
- Tanker, 142
 - hazard, 142
 - safety guide, 253
 - vessel, 249
 - work, 249–286
- Technical detail: lights and shapes, 115–120
- Telemotor transmission, 162
- Telescopic compass reflector unit, 47
- Tender ship, 71
- Temperature, 62
 - can, 256
- Testing mechanical hoists, 18
- Test meter (oxygen), 265
- Third adjustment sextant, 32–34
- Thrust units, 223–225
- Thunder, 62
- Tidal stream atlas, 9, 12
- Tide tables, 9, 11
- Tiller, 162
- Tipsy key, 35
- Tornado, 63
- Torque, 35
- Towing, 195, 243–248
- Towing and pushing, 99–102
- Trade winds, 63
- Traffic separation schemes, 92
- Training and drills, 141
- Transfer, 219, 221
- Transfer of oil, 279, 281
- Transmission line error, 28
- Tropical revolving storms, 76, 77
- Tropopause, 76
- Trough, 63
- Tugs, 242–248
- Turning circles, 219–223
- Turning short round, 234
- Tween deck fires, 174
- Twilight, 63
- Twin screw propulsion, 216, 217
- Types of rudder, 213
- Ullage, 256
 - pipe plan, 262
 - stick, 256
- Unbalanced plate rudder, 213
- Underway, 212
- Union purchase, 294
- United Kingdom buoyage direction, 136
- UK buoys, 136
- UK coastal forecast, 64
- Universal multi-angled fairlead, 228

SHIPHANDLING

-
- Urgency signal, 191
 - Use of anchors, 75
 - Use of sea anchors, 75
 - Use of storm oil, 74, 75
 - Use of tugs, 242

 - Veering, 63
 - Ventilation, 264
 - Vent valves, 263, 264
 - Vertex, 63
 - Very close pack ice, 82
 - Very large crude carrier, 249
 - Vessel, 87

 - Vessel in distress, 189
 - Virtual loss of GM, 152, 153
 - Visibility, 63
 - Visibility of lights, 97
 - Volatile liquid, 249

 - Warships, 125–126
 - Warm front, 63, 68
 - Watchkeeping duties, 3–9
 - Watertight doors, 148, 149
 - Watertight integrity, 147
 - Water wall system, 251
 - Washing cycles, 261

 - Wave scale, 67, 68
 - Way, 212
 - Weather chart, 64–66, 71
 - Weather report codes, 67, 68
 - Weather side, 212
 - Weekly notices to mariners, 9, 10
 - Wheel key, 254, 257
 - Whesoe tank gauge, 257, 258
 - Whistles, 121, 122
 - Wine carrier, 250
 - Winnets, 17

 - Yaw, 212

OSTMETC SHARED FILES
"NOT FOR SALE"